



Roll neck bearings for rolling mill



JTEKT

JTEKT CORPORATION

CAT. NO. B2013E

Preface

In 1943, JTEKT supplied bearings for rolling mills as the first domestic manufacturer in Japan. Since then, JTEKT has been cultivated advanced technology and technical know-how with customers. To meet with customers' requests, JTEKT strives for development of more highly precise and reliable bearings for rolling mills while using experience and actual achievement for technical development and research.

JTEKT will do a service by customer-oriented "monozukuri" (Japanese way of manufacturing) in the future.

Features of JTEKT products

1

High precision

JTEKT's highly precise bearings contribute to improvement in operating efficiency and reduction in energy consumption.

2

High reliability

JTEKT's highly reliable bearings obtained by actual achievement in long years contribute to stable operation.

3

Reduction in cost for maintenance and inspection

Development in new technology of bearings lengthens maintenance interval, and reduces cost and time for maintenance and inspection of bearings.

4

Total service of products for rolling mills

JTEKT, manufacturer of bearings, drive shafts, and oil seals, offers total service for these products.

Operating environment of bearings for rolling mill

Bearings in every industry are used under various kinds of severe conditions. For instance, bearings used in automobiles, railway stocks, and aircrafts are required to have ultimate reliability, as due to safety reasons, they are never allowed to fail during operation. While bearings used in machine tool spindles are required to have ultra-high rotational speed performance and high running accuracy. In these examples, operating environment is not so severe. Meanwhile, bearings for rolling mills must withstand heavy load and high speed rotation, as well as very severe operating environment. In various industries, they are used under severe conditions in every respects.

Load and rotational speed of bearings

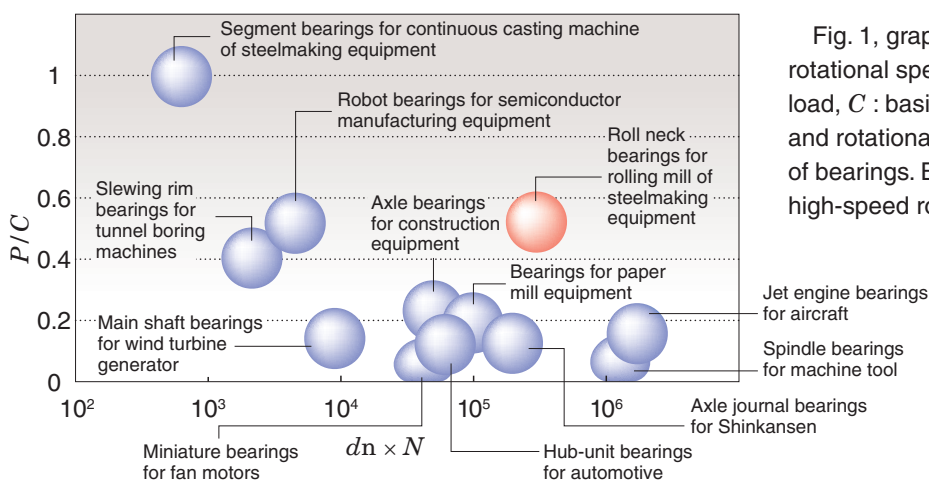

Fig. 1 Bearing load ratings and rotational speeds

Operating environment

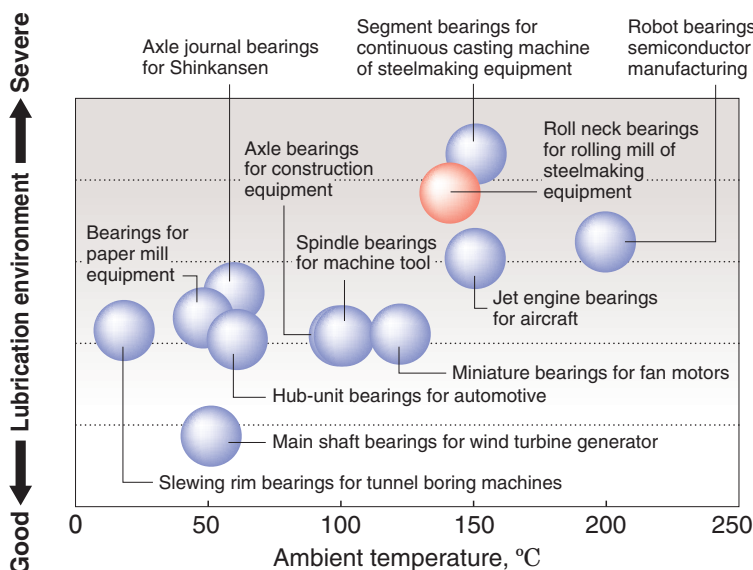

Fig. 2 Bearing ambient temperature and lubrication conditions

Roll neck bearings for rolling mill and relevant products

Four-row tapered roller bearing

Sealed type



These bearings, mainly used for work rolls or intermediate rolls, carry both of radial load and axial load at a time. Adjustment of internal clearance is not required, facilitating handling. Open type is also available.

Four-row cylindrical roller bearing

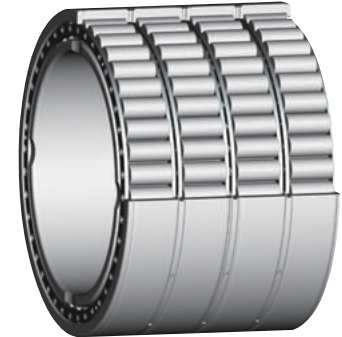

These bearings, used for back-up rolls, have a superior large radial load capacity, and are suitable for high-speed rotation. Rolling accuracy can be improved by applying the tight fitting of the inner ring onto the roll journal, and then applying the integral system grinding of the inner ring raceway. Additionally, the integral system grinding can be applied free adjustment of the bearing clearance.

Open type

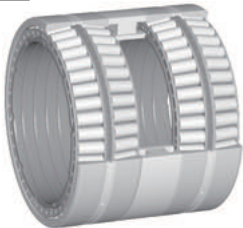

Four-row tapered roller bearing (45D type)



Four-row tapered roller bearing (TQO type)

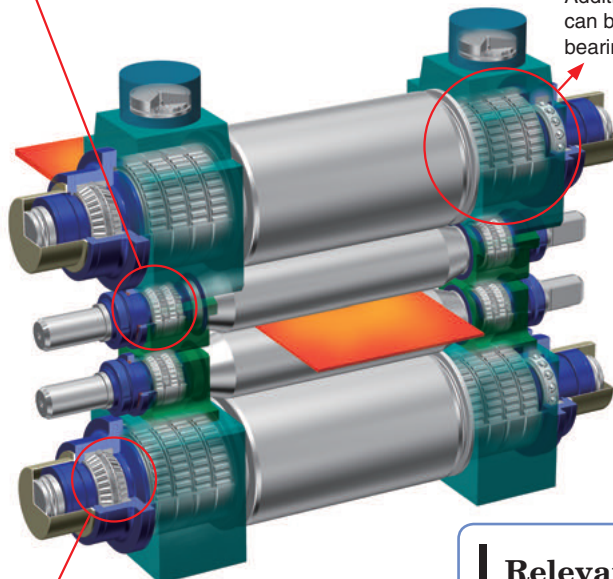

Double-row tapered roller bearing



(TDIS type)

These bearings, used for back-up rolls, have a large contact angle, and can load a large axial load. The inner ring has key way applicable to each key. If the outer ring must be preloaded, consult with JTEKT. We propose you of the recommended preload.

Relevant products

Drive shaft



For details of drive shafts, see CAT. NO.B2008E.

Oil seal

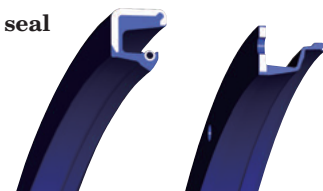

For details of oil seal, see CAT. NO.R2001E.

Sealed type four-row tapered roller bearing

Features

1. Substantial reduction in grease consumption (compared to open type)
2. Extension of overhaul and cleaning intervals
3. Prevention of intrusion of rolling mill oil and/or scale
4. Reduction in harmful effects on working environment
[compared to open type (grease lubrication, oil mist lubrication)]

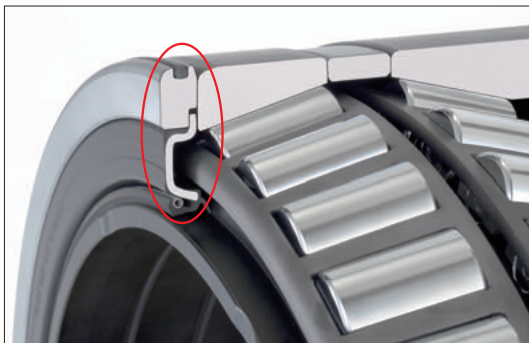

A. Seal cover with seal and O-ring

Seal with spring and O-ring prevent intrusion of rolling mill oil and scale causing leak of packed grease in the bearing. Newly-developed compact seal increases the load rating to 1.2 times compared to the conventional sealed type bearing, bearing service life to 1.8 times. (Ratio of our company)



B. Seal between inner rings

Seal prevents intrusion of rolling mill oil from roll necks. Integration of case (metal ring) and packing allows compact size and easy handling.

Comparison of cost for sealed type and open type

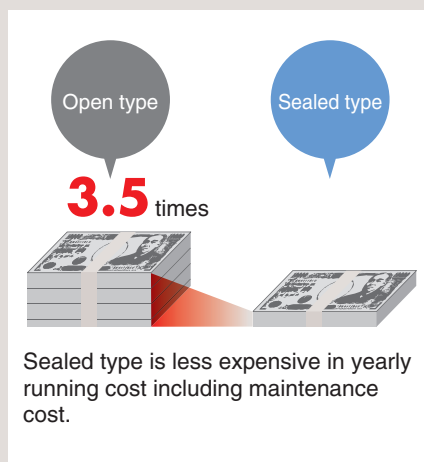

	Open type	Sealed type
Number of stands	5 stands/line	5 stands/line
Work roll (number of turnovers)	3 turnovers	3 turnovers
Number of bearings (4x5 standsx3 turnovers)	60 set	60 set
Initial amount of packed grease (kg)	1.00 kg	1.00 kg
Grease cost (Yen/kg)	¥500	¥2,000
Roll replacement interval (hour)	6 hours	6 hours
Operation (hour)	24 hours	24 hours
Greasing frequency per roll replacement	Once	0
Greasing amount per roll replacement (kg)/bearing	0.05 kg	0 kg
Greasing amount per roll replacement (kg)/line	1 kg	0 kg
Monthly greasing amount (kg)/line	120 kg	0 kg
Monthly greasing cost (Yen)/line	¥60,000	¥0
Yearly greasing amount (kg)/line	1 440 kg	0 kg
Yearly greasing cost (Yen)/line	¥720,000	¥0
Overhaul and cleaning interval (month)	3 months (four times/year)	6 months (twice/year)
Greasing amount per overhaul and cleaning (kg)/bearing	1 kg	1 kg
Yearly number of overhaul and cleaning bearings/line	240	120
Yearly greasing amount (kg)/line	240 kg	120 kg
Yearly greasing cost (Yen)/line	¥120,000	¥240,000
Yearly total of greasing cost (Yen)/line	¥840,000	¥240,000
	3.5	1

The currency unit is Japanese Yen.

Features of new products

Extended service life of sealed type four-row tapered roller bearing

JTEKT has developed the sealed type four-row tapered roller bearing with oil seals integrated for reduction of grease consumption and prevention of intrusion of foreign matters (rolling mill oil or scale) of rolling mill bearings, and contributed to reduction of pollution of surrounding environment due to grease leak and elimination of re-greasing. However, due to the extended overhaul and cleaning intervals, the damage due to their intrusions (wear and/or rust on raceway) has recently occurred. Therefore, JTEKT has pushed forward the project to improve the life of the sealed type four-row tapered roller bearings through failure mode analysis as shown in Fig. 3.

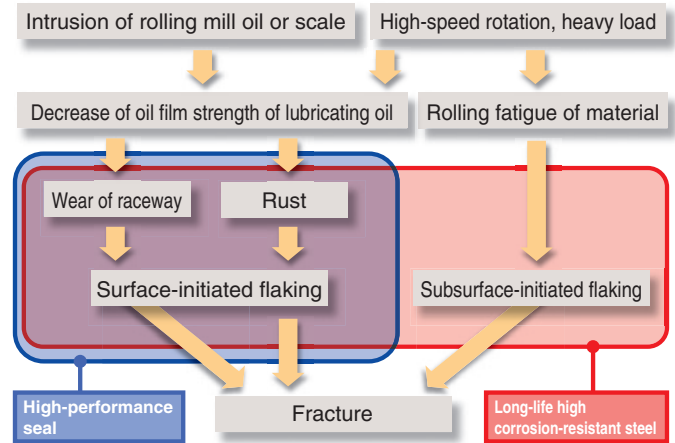

Fig. 3 Analysis of failure of sealed type four-row tapered roller bearing

High-performance seal

JTEKT dramatically extended bearing life by completely preventing the intrusion of rolling mill oil and/or scale into the bearing, which is the major cause of failure through the use of enhanced seals. Moreover, maintenance interval has been also lengthened by maintaining high sealing performance. This product was developed by collaboration of JTEKT and Koyo Sealing Techno Co.,Ltd. in JTEKT group.

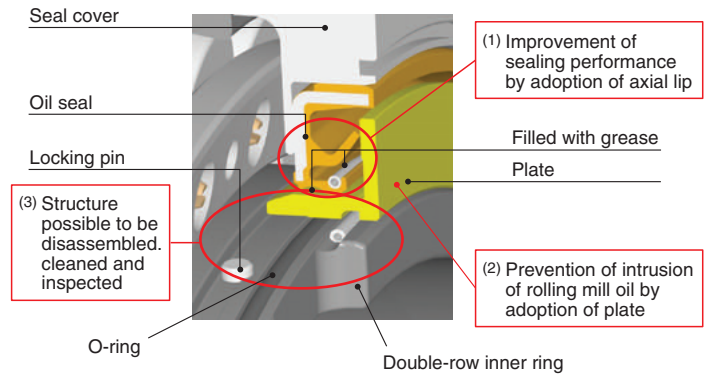

Fig. 4 Structure of high-performance seal

Fig. 5 and Table 1 show the appearance status and application history of bearing with high-performance seal adopted. Low water content in the grease and little to no rust generation is proof of excellent sealing performance.



Fig. 5 Post-use appearance of bearing with high-performance seal

Application	Hot strip mill work roll
Service period	1 486 h (Without any maintenance or re-greasing)
Bearing appearance	Good, no flaking and slight wear
Grease penetration	About 280 (New : 300)
Water content in grease	About 1%

Table 1 Application history of bearing with high-performance seal

Long-life, high corrosion-resistant steel

When rolling mill oil intrudes into the bearing, intrusion may cause rust between the raceway and the rollers, from which flaking is initiated. Also, the breakage of oil film due to the intrusion of rolling mill oil may cause wear on the rolling surfaces of raceways and rollers, from which surface-initiated flaking may occur. In order to improve both problems, JTEKT has developed a new long-life, high corrosion-resistant steel with optimized content of chromium and molybdenum. Additionally, original carbonitriding heat treatment has improved corrosion-resistance and wear-resistance qualities while maintaining the toughness of the steel.

Comparison of rust-resistance

Test result

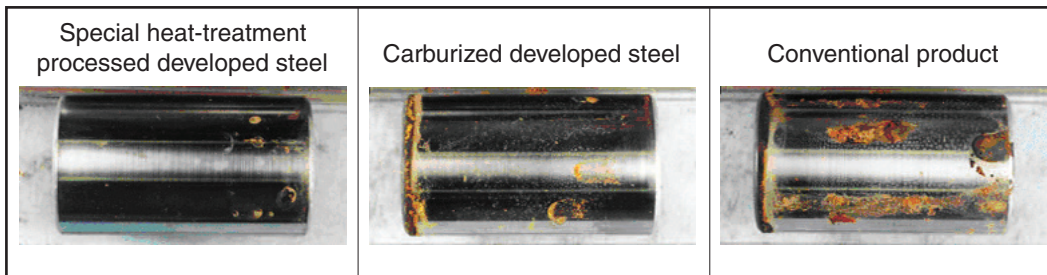

Special heat treatment : Carburizing + Carbonitriding

Fig. 6 Comparison of rust-resistance (humidity cabinet test)

● Humidity cabinet test conditions

Test temperature :
49 °C ± 1 °C
Relative humidity :
95% or more
Test period : 96 hours

Rolling fatigue life test

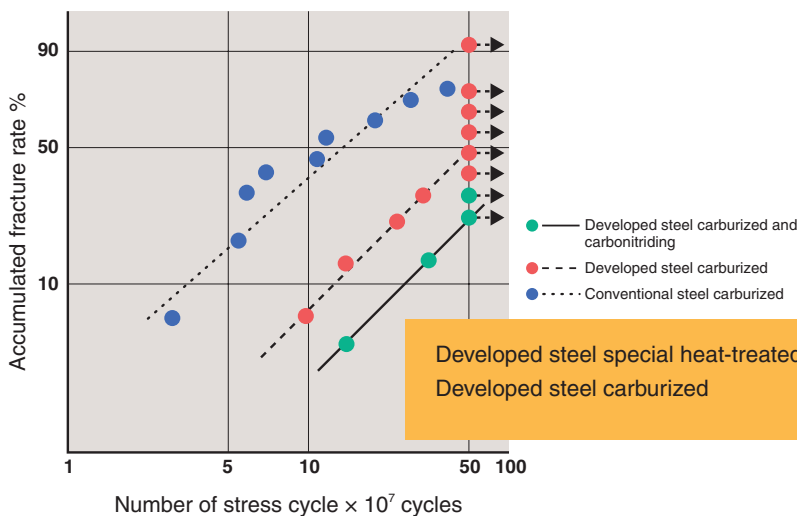

● Life test conditions

Test piece form : 20 mm dia.,
32 mm length
Maximum contact stress : 5 800 MPa
Loading cycle frequency : 285 Hz
Lubricating oil : Turbine oil (ISO #VG68)
Oil supply : 2 ℓ/min (room temperature)

*Test was banned after 50×10^7 time

Developed steel special heat-treated – seven times longer life
Developed steel carburized – four times longer life
(compared to JTEKT conventional product)

Fig. 7 Result of rolling fatigue life test

Fig. 8 and Table 2 show the appearance and application history of bearing with newly developed steel adopted. Restraining of flaking caused by rust can be seen.

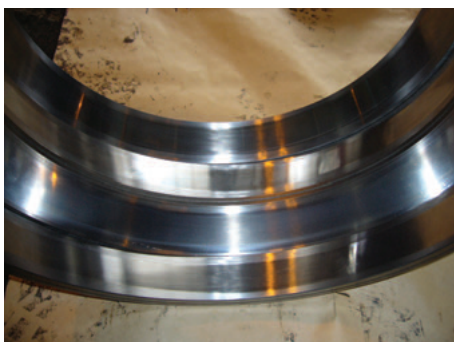

Fig. 8 Post-use appearance of bearing with newly developed steel

Application	Cold strip mill work roll
Service period	About 9months
Bearing appearance	No rust on outer ring raceway surface
Water content in grease	About 5%

Table 2 Application history of bearing with newly developed steel

Replacing oil film bearing with rolling bearing

In 1972, JTEKT adopted four-row cylindrical roller bearings for new cold tandem mill tandem back-up rolls (BUR) at first in Japan. Since then, JTEKT has supplied bearings for BUR to many steel manufacturers all over the world. Since JTEKT carried out the modification design and delivered rolling bearings for the modification of the plate mill by replacing the oil film bearing of the back-up roll with the rolling bearing in 1984, JTEKT has completed about twenty-five projects (maximum record in Japan) until 2007 and has contributed to offer highly-precise products for rolling mills.

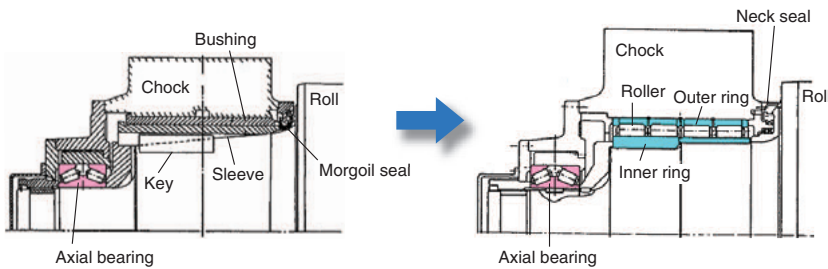

Fig. 9 Replacement of oil film bearing with rolling bearing for back-up roll of rolling mill

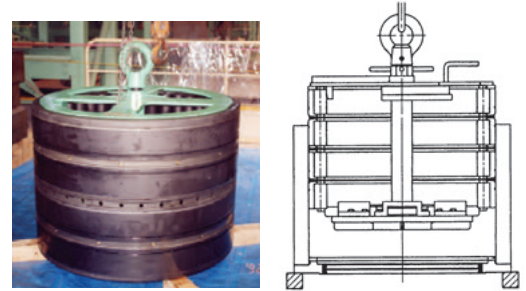

Fig. 10 Lifting tool for rolling bearing assembly

Oil Seal

JTEKT can supply oil seals for various purposes for rolling mills or feeding tables.

Features of Koyo oil seal

1. Lightweight, compact, and energy-saving

- Koyo oil seals offer high sealing performance, while being compact with reduced seal width.
- They help reduction of machine weight, size, and resource consumption.

2. High sealing performance by optimum lip design

- Koyo oil seals adopt a linear-contact lip, which provides proper radial lip load.
- The lip design ensures excellent sealing performance, low torque, proper flexibility and high allowability for eccentricity.

3. Low heat generation and long service life by highly self-lubricating rubber materials

- Based on extensive research and experimentation, JTEKT has succeeded in developing seal rubber materials with high self-lubrication performance. These rubber materials show limited chemical changes such as hardening, softening and/or aging.
- These materials, having excellent durability, can offer long service life with less heat generation even under high-peripheral speed.



Large-size oil seal

For details of oil seals, see CAT.NO.R2001E.

Bearing failures, causes and countermeasures

Failures

Characteristics

1

Flaking

Flaking caused by excessive axial load



(Inner ring of four-row tapered roller bearing)

Damages

Flaking on bearing raceway surface generated on only rows receiving axial load

Causes

- 1) Crossed work rolls causing excessive axial load
 - Roll neck diameter is smaller than the standard one.
 - Chock side liner is worn.
 - Inaccuracy of mill stand.
 - Rigidity of the chock is poor.
 - Corrosion on liner or clearance generated between the liner and the chock.
 - Failure of the keeper plate.

Countermeasures

- 1) Keep the correct locations of the chock and work roll.



(Outer ring raceway of four-row tapered roller bearing)

Damages

Flaking generated and developed from raceway end face

Causes

- 1) Looseness of chock cover/excessive axial clearance.
 - (As the axial clearance is increased, the loading range becomes narrower, partial load acts, and edge load is generated on the outer ring raceway.)
- 2) Excessive axial clearance is generated because of the mixed use of other bearing spacer or outer ring.

Countermeasures

- 1) Adjust shims, select thickness of shims, measure a gap, and tighten bolts correctly.
- 2) Use parts of the same number.

Flaking caused by improper mounting

Loading position (1)

Loading position (2)

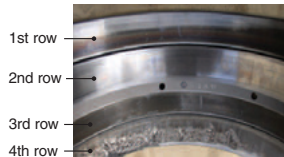

Loading position (3)

Loading position (4)



(Outer ring raceway of four-row tapered roller bearing)

Damages

Flaking on raceway surface with slanted contact

Causes



- 1) It occurs when the chock is fixed inappropriately and slantingly.
 - Failure of keeper plate
 - Removal, looseness, damage, deformation, bend, unequal tightening, unequal wear, improper parallelism.
 - Damaged, deformed, or bent chock flange.

Countermeasures

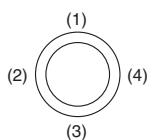
- 1) Find the cause of damage by periodic inspection of the chock and stand.

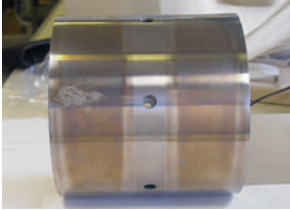
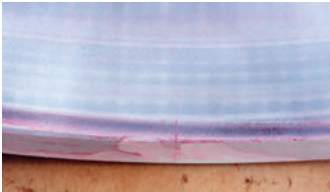

Bearing failures, causes and countermeasures

Failures	Characteristics	
1 Flaking	Flaking at corroded start point  (Outer ring raceway of four-row tapered roller bearing)	Damages Flaking on raceway surface started from corroded (rusted) portion <hr/> Causes <ol style="list-style-type: none"> 1) After the bearing was used, it has been left for a long period with moisture mixed in grease. 2) Improper rust preventive treatment after the bearing was washed. 3) Worn or damaged seal lips. 4) Corrosion on the raceway is generated due to the clearance between the roll neck and the sleeve, and flaking occurs with rust. <hr/> Countermeasures <ol style="list-style-type: none"> 1) Improve seal maintenance and sealing method. Periodically check for wear or damage on the seal lips. 2) Fit the "O" ring between the roll neck and the sleeve. 3) Immediately after the bearing is removed from the chock, change grease. 4) After washing the bearing, remove kerosene and water completely.
	Flaking on nicks (scratch) start point  (Rolling contact surface of four-row cylindrical roller bearing)	Damages Flaking on rolling contact surface with nicks start point <hr/> Causes <ol style="list-style-type: none"> 1) Inappropriate handling <ul style="list-style-type: none"> - Mounting / dismounting bearing to / from chock. - Replacing roll. <hr/> Countermeasures <ol style="list-style-type: none"> 1) Proper handling jig (use of a copper hammer). 2) Prevention of impact load when replacing roll (use of soft material). 3) Improvement in mounting method. 4) Change in raceway chamfering.
	 (Inner ring raceway of double-row cylindrical roller bearing)	Damages Flaking on raceway surface <hr/> Causes <ol style="list-style-type: none"> 1) Low viscosity oil lubrication (improper lubrication). 2) Ingress of dusts and foreign matters. <hr/> Countermeasures <ol style="list-style-type: none"> 1) Improvement in viscosity of oil and oil type. 2) Improvement in seal maintenance and sealing method. Periodic check of wear or damage of seal lip. 3) Check of oil filter.
2 Cracking Chipping	 (Inner ring side face of four-row tapered roller bearing)	Damages Minute crack on inner ring side face <hr/> Causes <ol style="list-style-type: none"> 1) Fix the inner ring and the roll with a fillet ring (thrust collar). 2) Clearance between the fillet ring (thrust collar) and the inner ring is excessively small. 3) Area of the side face of nut/slinger contacting the inner ring side face is too small, the side face is worn due to inner ring creep, causing heat. <hr/> Countermeasures <ol style="list-style-type: none"> 1) Keep the clearance between the inner ring and the fillet ring (thrust collar) (from 0.5 mm to 1.5 mm). 2) Keep the area of the side of fillet ring (thrust collar) (to reduce pressure on the side face). 3) Apply and supply grease of adequate amount.

Failures

Characteristics

2

Cracking
Chipping



(Rolling contact surface of four-row cylindrical roller bearing)

Damages

Cracking on rolling elements

Causes

- 1) Application of load greater than bearing load rating (Load resistance of roller by use of pin type cage)
- 2) Secondary factor in case of damaged pin of cage (For a reversible mill, pins are broken due to fatigue caused by rapid acceleration and deceleration)
- 3) Other factors
 - Ingress of water due to faulty sealing.
 - Increase of axial clearance of bearing, causing application of partial and excessive load.

Countermeasures

- 1) Optimal design of bearing considering load and operating conditions (Examination of optimal cage type)
- 2) Reviewing sealing method and design of strength of cover.

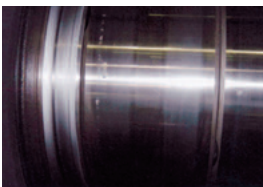

(Inner ring raceway of four-row cylindrical roller bearing)

Damages

Grinding burn or crack on inner ring raceway surface

Causes

- 1) After fitting an inner ring into the roll neck, grinding burn occurs during grinding with the inner ring and the roll.
- 2) Crack occurs because rollers rolling on the raceway surface of which strength (hardness) is decreased due to grinding burn.

Countermeasures

- 1) Reviewing grinding conditions
Grain size of grinding stone, grinding stone cutting amount, cutting pressure, grinding fluid amount, etc.



(Inner ring raceway of four-row cylindrical roller bearing)

Damages

Axial crack occurs on bore surface of inner ring and raceway surface.

Causes

- 1) Excessive interference between inner ring and shaft.
- 2) Great fit stress due to excessive difference in temperature of inner ring and that of shaft.

Countermeasures

- 1) Appropriate fit conditions of inner ring and shaft.
- 2) Appropriate difference in temperature by checking load, rotation, and temperature conditions. (appropriate fit)

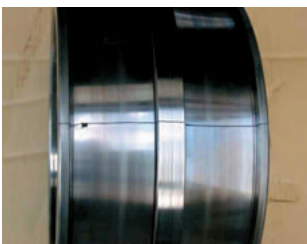

(Inner ring of spherical roller bearing)



(Fractured section of inner ring)

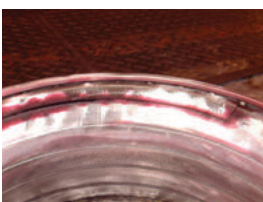

(Inner ring bore surface of four-row tapered roller bearing)

Damages

Circumferential crack occurs on bore surface and raceway surface of inner ring.







Causes

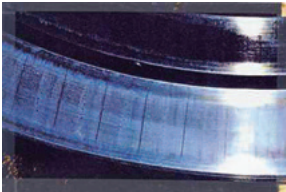

- 1) Step wear occurs on the shaft (roll neck), and the inner ring overrides the shaft, causing great bore surface stress.

Countermeasures

- 1) Provide circumferential groove for the roll neck.
- 2) When using a bearing with different chamfers for a roll, make the chamfers identical.

Bearing failures, causes and countermeasures

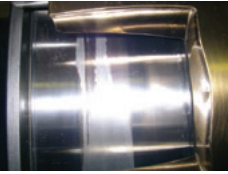
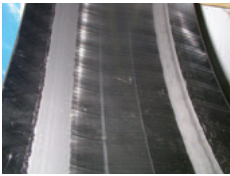
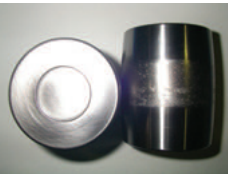
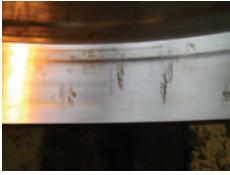
Failures	Characteristics		Damages	Causes	Countermeasures
2 Cracking Chipping	 <p>(Outer ring raceway of double-row tapered roller bearing)</p>	 <p>(Fractured section of outer ring)</p>	<p>Axial crack occurs on outside surface and raceway surface of outer ring.</p>	<ol style="list-style-type: none"> 1) Excessive axial load. 2) Axial clearance between the bearing and roll is great, and excessive axial load is applied. 	<ol style="list-style-type: none"> 1) Check for axial load. 2) Check the wear condition of counterpart components. 3) Reviewing thickness of the outer ring
	 <p>(Inner ring raceway of spherical thrust roller bearing)</p>	 <p>(Assembly of tapered roller bearing)</p>	<p>Crack occurs on inner ring back face rib.</p>	<ol style="list-style-type: none"> 1) Excessive axial load. 2) Low holding shoulder diameter on the inner ring back face rib. 	<ol style="list-style-type: none"> 1) Reviewing operating conditions. 2) Reviewing dimensions of counterpart collar. (Dimensions allowing backup of inner ring back face rib)
3 Brinelling Nicks	 <p>(Outer ring raceway surface of four-row tapered roller bearing)</p>	 <p>(Rolling contact surface of four-row cylindrical roller bearing)</p>	<ol style="list-style-type: none"> 1) Brinelling (Nicks) on raceway and rolling contact surfaces (scratch). 2) Brinelling on raceway surface at the same interval as rolling element spacing. 	<ol style="list-style-type: none"> 1) Nicks occur on the raceway and rollers because of improper handling. <ul style="list-style-type: none"> · Mounting / dismounting bearing to / from chock · Replacing roll 2) Great bending load is applied to the roll neck. (Especially, when faulty rolling occurs) 	<ol style="list-style-type: none"> 1) Proper handling jig (use of a copper hammer). 2) Application of grease to raceway surface of inner and outer rings. (Apply oil if the bearing is the oil lubricated type) 3) Prevention of impact load when replacing roll. (Use of soft material) 4) Roll bending compared to bearing static load rating. 5) Improvement in mounting method. 6) Change in raceway chamfering. 7) Check for excessive load on the slant chamfer of the raceway surface.
	 <p>(Roller end face of double-row cylindrical roller bearing)</p>	 <p>(Outer ring rib of double-row cylindrical roller bearing)</p>	<p>Scuffing on roller end face, rib of the raceway</p>	<ol style="list-style-type: none"> 1) Improper lubrication, ingress of foreign matters. 2) Abnormal axial load caused by improper mounting or control of bearing overall thickness. 3) Excessive axial load. 4) Excessive preload. 	<ol style="list-style-type: none"> 1) Selection of appropriate oil type and supply of adequate lubricant. 2) Reviewing bearing mounting location. 3) Reviewing bearing overall thickness control. 4) Reviewing operating conditions. 5) Checking preload.
4 Scratch Scuffing	 <p>(Roller large end face of double-row tapered roller bearing)</p>				

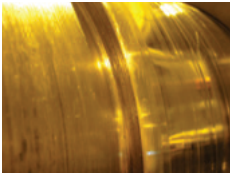
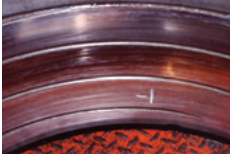
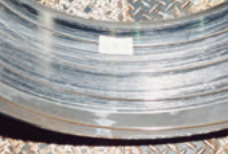
Failures	Characteristics			
<p>5 Smearing</p>	 <p>(Outer ring raceway surface of four-row tapered roller bearing)</p>	 <p>(Outer ring raceway surface of spherical roller bearing)</p>	<p>Damages</p> <p>Smearing on raceway or rolling contact surface</p>	
	 <p>(Outer ring raceway surface of spherical roller bearing)</p>	 <p>(Rolling element surface of spherical roller bearing)</p>	<p>Causes</p> <ol style="list-style-type: none"> 1) Improper lubrication 2) Slip of rolling elements (high speed, light load) 3) Ingress of foreign matters during maintenance 	
			<p>Countermeasures</p> <ol style="list-style-type: none"> 1) Selection of appropriate oil type and supply of adequate lubricant 2) Setup of appropriate preload 3) Prevention of ingress of foreign matters 	
<p>6 Rust Corrosion</p>	<p>Corrosion</p>  <p>(Outer ring of four-row tapered roller bearing)</p>	 <p>(Outer ring of four-row tapered roller bearing)</p>	<p>Damages</p> <p>Rust, corrosion on the raceway surface at the same interval as rolling element spacing</p>	
			<p>Causes</p> <ol style="list-style-type: none"> 1) Worn or damaged seal lips 2) Ingress of water or corrosive materials into clearance between roll neck and sleeve 	
	<p>Rust</p>  <p>(Outer ring of four-row tapered roller bearing)</p>		<p>Countermeasures</p> <ol style="list-style-type: none"> 1) Improve seal maintenance and sealing method. Periodically check for wear or damage on the seal lips. 2) Fit the "O" ring between the roll neck and the sleeve. 	
<p>7 Creeping</p>	 <p>(Scuffing on rolling mill roll neck)</p>		<p>Damages</p> <p>Wear, discoloration, and scuffing due to slip of fitting surface</p>	
	 <p>(Inner ring bore surface of four-row tapered roller bearing)</p>		<p>Causes</p> <ol style="list-style-type: none"> 1) Insufficient grease or oil between the inner ring bore surface and the roll neck outside surface (When creep occurs between the inner ring and the roll neck, because of loose fit of them.) 	
			<p>Countermeasures</p> <ol style="list-style-type: none"> 1) Provide the spiral groove for bore surface of inner ring 2) When mounting the bearing, apply grease with molybdenum disulfide or EP grease. (Apply oil if the bearing is the oil lubricated type) 	

Bearing failures, causes and countermeasures

Failures	Characteristics					
8 Seizure	 <p>(Rolling contact surface of double-row tapered roller bearing)</p>	 <p>(Roller large end face of double-row tapered roller bearing)</p>	<div style="border: 1px solid black; padding: 5px; margin-bottom: 5px;">Damages</div> Discoloration, deformation, and melting caused by heating in bearing <hr/> <div style="border: 1px solid black; padding: 5px; margin-bottom: 5px;">Causes</div> 1) Improper lubrication (insufficient or degraded lubricant) 2) Ingress of water due to faulty sealing 3) Excessive axial load 4) Heat generated by creep of inner ring 5) Ingress of dusts or foreign matters 6) Excessively small bearing internal clearance <hr/> <div style="border: 1px solid black; padding: 5px; margin-bottom: 5px;">Countermeasures</div> 1) Reviewing sealing type and conditions 2) Reviewing lubricating method and lubricant, and checking lubricated condition 3) Check for axial load 4) Reviewing bearing (type, size, etc.) 5) Reviewing clearance 6) Confirming operating conditions			
	 <p>(Inner ring of double-row tapered roller bearing)</p>					
	9 Failure in lubrication	 <p>(Inner ring assembly of four-row tapered roller bearing)</p>			<div style="border: 1px solid black; padding: 5px; margin-bottom: 5px;">Damages</div> Grease including large quantity of water mixed in <hr/> <div style="border: 1px solid black; padding: 5px; margin-bottom: 5px;">Causes</div> 1) Operated at high temperature ⇒ Grease is carbonized. 2) Ingress of water due to improper sealing or wear or damage of seal lip (In this example, 20% or more of water is mixed in grease.) <hr/> <div style="border: 1px solid black; padding: 5px; margin-bottom: 5px;">Countermeasures</div> 1) Find the cause of high temperature. (If the temperature cannot be lowered, review the possibility of change to high temperature grease.) 2) Checking wear or damage of seal lip Find the cause of and countermeasure against the improper sealing.	
		 <p>(Inner ring assembly of double-row tapered roller bearing)</p>		 <p>(Outer ring of double-row tapered roller bearing)</p>		<div style="border: 1px solid black; padding: 5px; margin-bottom: 5px;">Damages</div> Foreign matter attachment and corrosion occur because of ingress of a great deal of foreign matters (scale and water for rolling). <hr/> <div style="border: 1px solid black; padding: 5px; margin-bottom: 5px;">Causes</div> 1) Ingress of water due to improper sealing or wear or damage of seal lip <hr/> <div style="border: 1px solid black; padding: 5px; margin-bottom: 5px;">Countermeasures</div> 1) Checking wear or damage of seal lip Find the cause of and countermeasure against the improper sealing.
		 <p>(Four-row tapered roller bearing)</p>				
	 <p>(Outer ring assembly of four-row cylindrical roller bearing)</p>	 <p>(Outer ring assembly of four-row cylindrical roller bearing)</p>	<div style="border: 1px solid black; padding: 5px; margin-bottom: 5px;">Damages</div> Seizure and adhesion of raceway, roller, and cage <hr/> <div style="border: 1px solid black; padding: 5px; margin-bottom: 5px;">Causes</div> 1) Varied factors including improper lubrication, improper operation, and ingress of foreign matters occur, causing damages. <hr/> <div style="border: 1px solid black; padding: 5px; margin-bottom: 5px;">Countermeasures</div> 1) Checking improper operation 2) Checking lubricating conditions 3) Checking degradation of peripheral parts			
			<div style="border: 1px solid black; padding: 5px; margin-bottom: 5px;">Damages</div> Looseness and breaking of pin <hr/> <div style="border: 1px solid black; padding: 5px; margin-bottom: 5px;">Causes</div> 1) Abnormal load due to vibration occurs. 2) End of cage's service life because of use for a long period <hr/> <div style="border: 1px solid black; padding: 5px; margin-bottom: 5px;">Countermeasures</div> 1) Checking abnormal vibration 2) Replace if it has been used for a long period.			

[Reference]

Repair to portion flaking occurred

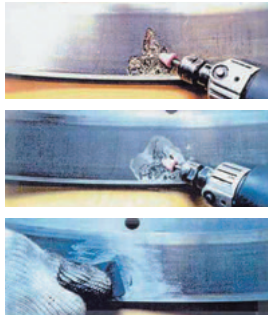

- 1 Remove the edges of the portion flaking occurred (with a polishing grinder).
- 2 Finish of the surface of the portion flaking occurred.
- 3 Finish the surface by lapping the modified portion.

Modification may not be able to be done depending on the status of the portion flaking occurred. Consult with JTEKT.

Particular failure cases of sealed type bearing

Checking oil seals and O-rings

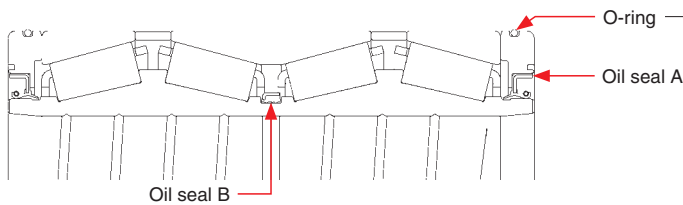

Cut, peeling, and yielding of O-ring for seal cover

Remedy Replace with new O-rings.

Hardening of oil seal A

Remedy Replacement is recommended.

Crack, blister of oil seal A

- Remedy**
- 1 Replace the oil seal. (The figure on the left side shows cracks on the sealing lip and minor lip).
 - 2 If they occurred in a short period, reviewing operating conditions or examination of change of oil seal material are required.

Abnormal wear to lip of oil seal A

- Remedy**
- 1 If the interference is restricted, replacement is required.
 - 2 When fitting new oil seals, apply grease to the lips generously.

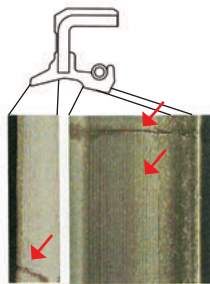

Abnormal wear to side and bore surfaces of oil seal B

- Remedy**
- 1 If the interference is restricted, replacement is required.
 - 2 When fitting new oil seals, apply grease to the side and bore surfaces generously.

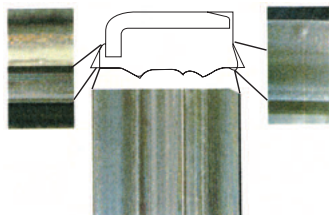

Oil seals and O-rings

- 1 Oil seals and O-rings are very important parts to prevent intrusion of water and foreign matters into bearings. Periodic replacement is required, since they are consumables.
- 2 Whenever attaching new oil seals or removed oil seals after overhaul and cleaning, be sure to apply grease to the oil seal lips generously. Service life of seals depends on the grease status.

Sealed type four-row tapered roller bearings

d 220 ~ (440) mm

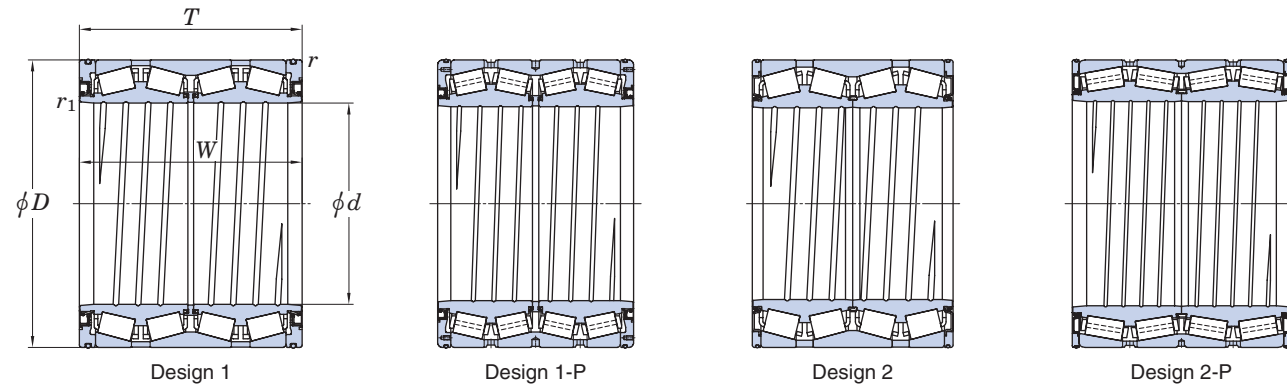

Boundary dimensions										Basic load ratings (kN)		Bearing No.	Design	Constant e	Axial load factors		(Refer.) Mass (kg)
d	D	T	W	r	$r_1^{1)}$	C_r	C_{0r}	Y_2	Y_3								
mm	inch	mm	inch	mm	inch	mm	inch	min.	min.								
220	—	320	—	290	—	290	—	3	2	2 200	4 700	47TS443229B	1	0.39	1.74	2.59	73.9
240	—	320	—	294	—	294	—	4	1	1 880	4 760	47TS483229-1	1	0.33	2.03	3.02	63.6
	—	338	—	248	—	248	—	3	1.5	1 890	4 120	47TS483425B	1	0.47	1.43	2.12	66
	—	338	—	340	—	340	—	3	1	2 450	5 930	47TS483434A	1	0.4	1.68	2.5	88
241.478	9.5070	349.148	13.7460	228.600	9.0000	228.600	9.0000	3.2	SP	2 000	4 110	47TS483523A	2	0.35	1.91	2.84	67.5
245	—	345	—	310	—	310	—	3	1.5	2 520	6 020	47TS493531-2	1	0.4	1.68	2.5	89.9
250	—	365	—	270	—	270	—	3	1.5	2 260	4 730	47TS503727A-1	1	0.4	1.68	2.5	94.2
254.000	10.0000	358.775	14.1250	269.875	10.6250	269.875	10.6250	3.2	1.5	2 520	6 010	47TS513627B	2	0.4	1.68	2.5	85
260	—	365	—	340	—	340	—	3.5	1.6	2 800	6 530	47TS523734-5	1	0.4	1.68	2.5	110
266.700	10.5000	355.600	14.0000	228.600	9.0000	230.188	9.0625	3.2	1.6	1 940	4 880	47TS533623B	2	0.36	1.87	2.79	60
276.225	10.8750	393.700	15.5000	269.875	10.6250	269.875	10.6250	3.2	SP	2 770	6 510	47TS553927A	2	0.4	1.68	2.5	105
279.400	11.0000	393.700	15.5000	269.875	10.6250	269.875	10.6250	3.2	SP	2 770	6 510	47TS563927B	2	0.4	1.68	2.5	101
	11.0000	393.700	15.5000	320.000	12.5984	320.000	12.5984	3.2	1.5	2 880	6 900	47TS563932-2	1	0.4	1.68	2.5	124
280	—	380	—	290	—	290	—	3.2	SP	2 720	6 940	47TS563829A	2	0.33	2.03	3.02	93.8
	—	395	—	340	—	340	—	3	1.5	2 960	7 110	47TS564034A	1	0.4	1.68	2.5	130
	—	410	—	268	—	268	—	5.4	1.6	2 240	4 510	47TS564127	1	0.33	2.03	3.02	118
	—	430	—	350	—	350	—	3.5	1.5	3 940	8 190	47TS564335	1	0.4	1.68	2.5	178
304.648	11.9940	438.048	17.2460	279.400	11.0000	279.400	11.0000	3.2	1.6	3 140	6 860	47TS614428C-1	2	0.4	1.68	2.5	135
304.902	12.0040	412.648	16.2460	266.700	10.5000	266.700	10.5000	3.2	0.8	2 750	6 820	47TS614127D	2	0.39	1.74	2.59	99.5
310	—	430	—	310	—	310	—	3	1	3 010	6 880	47TS624331-4	1	0.4	1.68	2.5	131
	—	430	—	350	—	350	—	3.5	SP	3 280	7 870	47TS624335B-2	1	0.4	1.68	2.5	148
317.500	12.5000	447.675	17.6250	367.000	14.4488	367.000	14.4488	4	1.6	3 680	8 500	47TS644537-1	1	0.4	1.68	2.5	176
343.052	13.5060	457.098	17.9960	254.000	10.0000	254.000	10.0000	3.2	0.8	2 870	7 030	47TS694625D-1	2	0.4	1.68	2.5	110
	13.5060	457.098	17.9960	299.000	11.7717	299.000	11.7717	3.2	SP	3 310	9 010	47TS694630B	2	0.4	1.68	2.5	135
355.600	14.0000	482.600	19.0000	269.875	10.6250	265.112	10.4375	3.2	1.5	2 680	6 090	47TS714827	1-P	0.47	1.43	2.12	134
360	—	480	—	375	—	375	—	3	1	4 120	10 600	47TS724838A	1	0.4	1.68	2.5	181
440	—	590	—	480	—	480	—	4	SP	6 870	18 700	47TS885948A-3	2-P	0.26	2.55	3.8	362

[Note] 1) SP indicates the specially chamfered form.

Sealed type four-row tapered roller bearings

d (440) ~ 800 mm

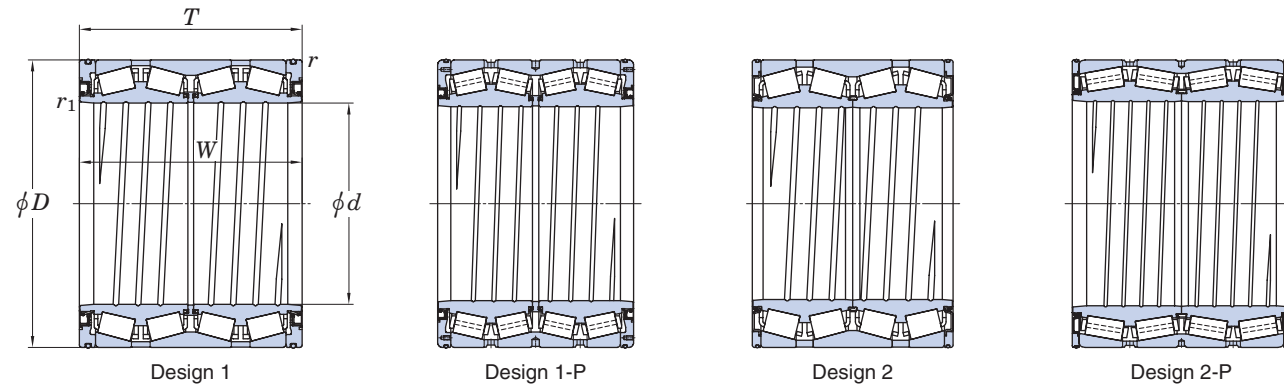

Boundary dimensions										Basic load ratings (kN)		Bearing No.	Design	Constant e	Axial load factors		(Refer.) Mass (kg)
d	D	T	W	r	r_1	C_r	C_{0r}	Y_2	Y_3								
mm	inch	mm	inch	mm	inch	mm	inch	min.	min.								
440	—	620	—	454	—	454	—	4	1.5	6 580	16 100	47TS886245-1	1-P	0.33	2.03	3.02	430
479.425	18.8750	679.450	26.7500	495.300	19.5000	495.300	19.5000	6.4	2	8 030	19 600	47TS966850	1-P	0.33	2.03	3.02	562
482.600	19.0000	615.950	24.2500	330.200	13.0000	330.200	13.0000	3.2	1.6	4 510	12 400	4TRS19D	2-P	0.4	1.68	2.5	239
492	—	655	—	480	—	480	—	5	1.5	7 450	21 200	47TS986648	1-P	0.33	2.03	3.02	449
585.788	23.0625	771.525	30.3750	479.425	18.8750	479.425	18.8750	6.4	1.5	8 730	24 400	4TRS586A	1-P	0.33	2.03	3.02	613
595.312	23.4375	844.550	33.2500	615.950	24.2500	615.950	24.2500	6.4	3.6	12 700	32 200	4TRS595B	1-P	0.33	2.03	3.02	1 120
609.600	24.0000	787.400	31.0000	361.950	14.2500	361.950	14.2500	6.4	3.2	5 920	14 900	4TRS610	1-P	0.4	1.68	2.5	430
711.200	28.0000	914.400	36.0000	387.350	15.2500	387.350	15.2500	6.4	3.2	7 160	19 400	4TRS711A	1-P	0.38	1.78	2.65	615
	28.0000	914.400	36.0000	420.000	16.5354	420.000	16.5354	6.4	3.2	7 870	22 200	4TRS711L	1-P	0.4	1.68	2.5	678
800	—	1 130	—	780	—	780	—	6	1.5	21 900	58 800	4TRS800	1-P	0.26	2.55	3.8	2 520

Four-row tapered roller bearings ... 45D type

d 360 ~ 685.800 mm

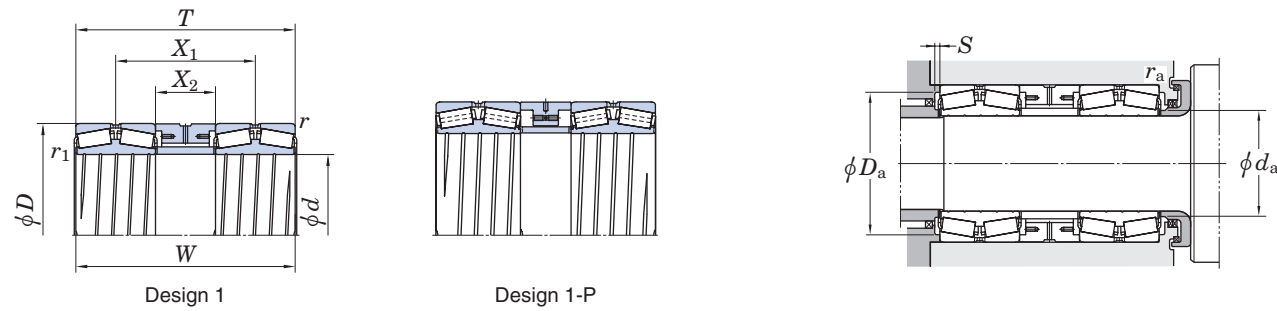

Boundary dimensions												Basic load ratings (kN)		Bearing No. ¹⁾	Design	Mounting dimensions (mm)						Constant e	Axial load factors			(Refer.) Mass (kg)	
d	D	T	W	X_1	X_2	r	r_1	C_r	C_{0r}	d_a	D_a	S	r_a			r_b	Y_2	Y_3	Y_0								
mm	inch	mm	inch	mm	inch	mm	inch	mm	mm	min.	min.	mm	mm	min.	max.	max.	min.	max.	max.								
360	—	450	—	350	—	350	—	225	100	2	1.5	2 660	7 460		45D724535	1	380	440	425	5.5	2	1.5	0.29	2.32	3.45	2.26	109
385.762	15.1875	514.350	20.2500	317.500	12.5000	317.500	12.5000	164.500	11.500	3.2	3.2	4 380	11 000		45D775132	1	415	503	483	9	3.2	3.2	0.26	2.55	3.8	2.5	180
400	—	530	—	370	—	370	—	202	34	3	1	4 930	12 900		45D805337	1	428	516	497	11.5	2.5	1	0.26	2.55	3.8	2.5	213
406.400	16.0000	562.000	—	381.000	—	381.000	—	196.924	12.700	6.4	3.2	5 990	15 000		45D815638	1	439	545	524	9.5	6.4	3.2	0.33	2.03	3.02	1.98	286
431.800	17.0000	571.500	22.5000	400.000	15.7480	400.000	15.7480	238.075	76.150	6.4	3	4 790	12 500		45D865740	1-P	460	554	536	10.5	6.4	3	0.36	1.87	2.79	1.83	281
460	—	680	—	390	—	390	—	225	60	5	1.5	6 020	13 700		45D926839	1	518	658	619	11.5	4	1.5	0.36	1.87	2.79	1.83	429
482	—	632	—	520	—	520	—	320	120	1.5	1.5	6 840	18 800		45D966352A	1-P	510	623.5	593	7	2	1.5	0.26	2.55	3.8	2.5	416
482.600	19.0000	615.950	24.2500	500.000	19.6850	500.000	19.6850	314.250	182.500	6.4	6.4	4 830	13 400		45D976250A	1-P	512	599	583	6.5	6.4	6.4	0.44	1.54	2.3	1.51	358
509.948	20.0767	654.924	25.7844	500.000	19.6850	500.000	19.6850	310.000	120.000	3	1.5	6 450	19 000		4TR510C	1-P	539	642	617	10	3	1.5	0.28	2.43	3.61	2.37	405
510	—	655	—	379	—	377	—	199.5	12	5	2	6 540	18 600		4TR510L-2	1-P	540	633	619	9	4	2	0.26	2.55	3.8	2.5	320
558.800	22.0000	736.600	29.0000	514.000	20.2362	514.000	20.2362	293.337	72.674	6.4	3.2	8 990	25 500		4TR559P-1	1-P	595	719	693	11.5	6.4	3.2	0.33	2.03	3.02	1.98	576
685.800	27.0000	876.300	34.5000	580.000	22.8346	580.000	22.8346	340.000	100.000	6.4	3.2	11 000	34 900		4TR686J	1-P	730	859	829	14	6.4	3.2	0.26	2.55	3.8	2.5	875

[Note] 1) While metric series bearings have minus tolerances for bore and OD, inch series have plus tolerances. Refer to page 47 for details of applicable tolerance standards.

Four-row tapered roller bearings ... TQO type

d 170 ~ 279.578 mm

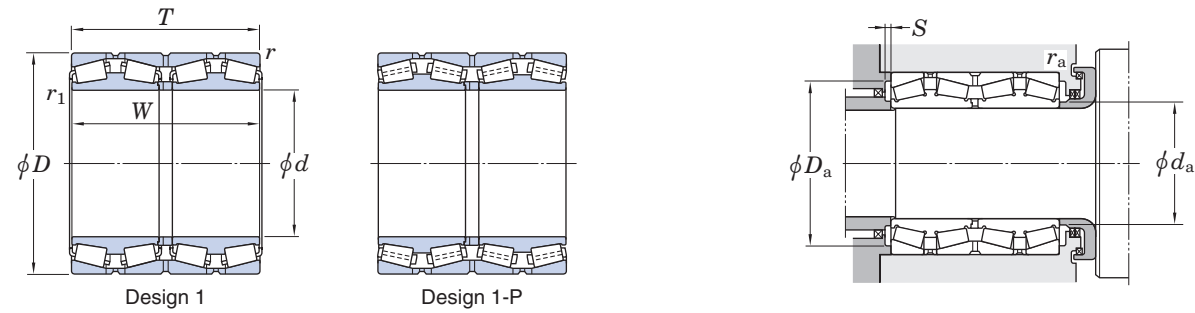

		Boundary dimensions								Basic load ratings (kN)		Bearing No. ¹⁾	De-sign	Mounting dimensions (mm)						Con-stant e	Axial load factors			(Refer.) Mass (kg)
d	D	T	W	r	r_1	C_r	C_{0r}	d_a	D_a	S	r_a			r_b	Y_2	Y_3	Y_0							
mm	inch	mm	inch	mm	inch	mm	inch	min.	min.			max.	max.	min.	min.	max.	max.							
170	—	240	—	175	—	175	—	2.5	3	1 020	2 310	37234A	1	189	228	218	5	2	2.5	0.33	2.03	3.02	1.98	24.2
180	—	254	—	185	—	185	—	2.5	3	1 140	2 550	37236	1	198	242	232	6	2	2.5	0.33	2.03	3.02	1.98	29.1
187	—	270	—	210	—	210	—	2.5	1	1 660	3 570	47T372721B	1	205	258	248	8	2	1	0.33	2.03	3.02	1.98	39.1
187.325	7.3750	269.875	10.6250	211.138	8.3125	211.138	8.3125	3.2	1.6	1 410	3 220	M238849D/810/810D	1	206	257	245	5	3.2	1.6	0.33	2.03	3.02	1.98	39.5
190	—	268	—	196	—	196	—	2.5	3	1 210	2 760	37238	1	210	256	246	6	2	2.5	0.33	2.03	3.02	1.98	33.4
190.500	7.5000	266.700	10.5000	188.913	7.4375	187.325	7.3750	3.2	1.6	1 160	2 810	67885D/67820/67820D	1	208.5	255.3	245.1	6	3.2	1.6	0.48	1.42	2.11	1.38	32.4
200	—	282	—	206	—	206	—	2.5	3	1 490	3 380	37240	1	223	270	260	5.5	2	2.5	0.28	2.43	3.61	2.37	39.6
216.103	8.5080	330.200	13.0000	269.875	10.6250	263.525	10.3750	3.2	1.6	2 500	5 120	47T433327	1	237	316	300	7	3.2	1.6	0.46	1.47	2.19	1.44	81.6
220	—	300	—	230	—	230	—	2.5	3	1 750	4 040	47T443023	1	231	288	278	6.5	2	2.5	0.40	1.68	2.50	1.64	45.1
	—	310	—	226	—	226	—	3	4	1 690	3 880	37244	1	242	296	285	6	2.5	3	0.33	2.03	3.02	1.98	52
	—	320	—	250	—	250	—	2.5	3	1 930	4 230	47T443225	1	244	308	293	6.5	2	2.5	0.35	1.95	2.90	1.91	64.7
	—	330	—	260	—	260	—	3	1	2 350	5 070	47T443326A	1	243	316	299	9	2.5	1	0.40	1.68	2.50	1.64	78.4
220.663	8.6875	314.325	12.3750	239.713	9.4375	239.713	9.4375	3.2	1.6	2 100	4 890	M244249D/210/210D	1	241	300	288	5	3.2	1.6	0.33	2.03	3.02	1.98	59
228.600	9.0000	311.150	12.2500	200.025	7.8750	200.025	7.8750	3.2	1.6	1 660	3 760	LM245149D/110/110D	1	247	297	287	5.5	3.2	1.6	0.33	2.03	3.02	1.98	41.8
240	—	338	—	248	—	248	—	3	4	2 360	5 360	37248	1	259	324	312	8.5	2.5	3	0.39	1.74	2.59	1.70	68.4
241.478	9.5070	349.148	13.7460	228.600	9.0000	228.600	9.0000	3.2	1.6	2 190	4 920	47T483523A	1	267	335	319	8.5	3.2	1.6	0.35	1.91	2.84	1.86	72.9
244.475	9.6250	327.025	12.8750	193.675	7.6250	193.675	7.6250	3.2	1.6	1 470	3 500	47T493319	1	259	313	303	5.5	3.2	1.6	0.55	1.24	1.84	1.21	44.4
	9.6250	327.025	12.8750	193.675	7.6250	193.675	7.6250	3.2	1.6	1 570	3 780	LM247748D/710/710D	1	265	313	305	7.5	3.2	1.6	0.32	2.10	3.13	2.06	44.4
250	—	365	—	270	—	270	—	3	1.5	2 650	6 340	47T503627	1	277	351	330	8	2.5	1.5	0.33	2.03	3.02	1.98	96.7
254.000	10.0000	358.775	14.1250	269.875	10.6250	269.875	10.6250	3.2	3.2	2 650	6 340	M249748D/710/710D	1	277	345	330	8	3.2	3.2	0.33	2.03	3.02	1.98	86
260	—	368	—	268	—	268	—	4	5	2 510	6 020	37252	1	286	350	338	6	3	4	0.33	2.03	3.02	1.98	88.4
266.700	10.5000	355.600	14.0000	228.600	9.0000	230.188	9.0625	3.2	1.6	2 230	5 690	47T533623B	1	285	342	332	8	3.2	1.6	0.36	1.87	2.79	1.83	62.7
279.400	11.0000	393.700	15.5000	269.875	10.6250	269.875	10.6250	6.4	1.6	2 660	5 990	47T563927B	1	305	373	363	9.5	6.4	1.6	0.40	1.68	2.50	1.64	101
279.578	11.0070	380.898	14.9960	244.475	9.6250	244.475	9.6250	3.2	1.6	2 280	5 650	LM654644D/610/610D	1	303	367	356	6.5	3.2	1.6	0.43	1.57	2.34	1.53	80.4

[Note] 1) While metric series bearings have minus tolerances for bore and OD, inch series have plus tolerances. Refer to page 47 for details of applicable tolerance standards.

Four-row tapered roller bearings ... TQO type

d 280 ~ (380) mm

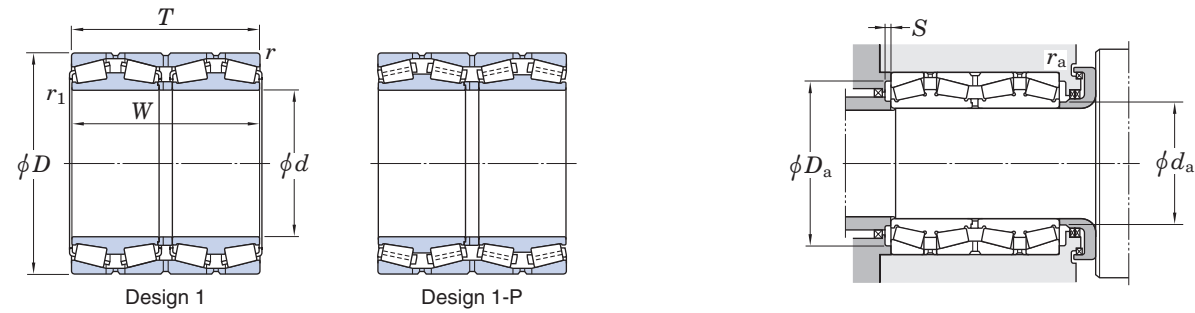

Boundary dimensions										Basic load ratings (kN)		Bearing No. ¹⁾	De-sign	Mounting dimensions (mm)						Con-stant e	Axial load factors			(Refer.) Mass (kg)
d	D	T	W	r	r_1	C_r	C_{0r}	d_a	D_a	S	r_a			r_b	Y_2	Y_3	Y_0							
mm	inch	mm	inch	mm	inch	mm	inch	min.	min.			max.	max.	min.	min.	max.	max.							
280	—	380	—	290	—	290	—	2	2	2 810	6 940	47T563829 37256X	1	300	370	354	6	2	2	0.33	2.03	3.02	1.98	91.8
	—	395	—	288	—	288	—	4	2	2 880	6 900		1	303	377	363	8	3	2	0.40	1.68	2.50	1.64	110
285.750	11.2500	380.898	14.9960	244.475	9.6250	244.475	9.6250	3.2	1.6	2 280	5 650	LM654648D/610/610D	1	303	367	356	6.5	3.2	1.6	0.43	1.57	2.34	1.53	75.6
288.925	11.3750	406.400	16.0000	298.450	11.7500	298.450	11.7500	3.2	3.2	3 450	8 840	M255449D/410/410D	1	316	392	373	9	3.2	3.2	0.34	2.00	2.97	1.95	127
300	—	420	—	310	—	310	—	3	1	3 390	8 050	47T604231 37260 47T604330	1	325	406	388	8.5	2.5	1	0.34	2.00	2.98	1.96	132
	—	424	—	310	—	310	—	4	5	3 000	6 570		1	334	406	391	6	3	4	0.28	2.37	3.53	2.32	134
	—	430	—	300	—	300	—	3	4	3 320	7 630		1	328	416	393	10	2.5	3	0.35	1.95	2.90	1.91	141
300.038	11.8125	422.275	16.6250	311.150	12.2500	311.150	12.2500	3.2	3.2	3 390	8 050	HM256849D/810/810D	1	325	407	388	7	3.2	3.2	0.34	2.00	2.98	1.96	136
304.800	12.0000	419.100	16.5000	269.875	10.6250	269.875	10.6250	6.4	1.6	2 840	6 950	M257149D/110/110D	1	331	398	387	7	6.4	1.6	0.33	2.03	3.02	1.98	110
304.902	12.0040	412.648	16.2460	266.7	10.5000	266.7	10.5000	3.2	3.2	2 990	7 280	M257248D/210/210D	1	328	398	383	7	3.2	3.2	0.32	2.12	3.15	2.07	101
310	—	430	—	310	—	310	—	3	3	3 520	8 420	47T624331A 47T6246A	1	332	416	399	10	2.5	2.5	0.40	1.68	2.50	1.64	135
	—	460	—	325	—	325	—	4	5	4 200	9 500		1	346	442	421	12	3	4	0.32	2.12	3.15	2.07	188
317.500	12.5000	422.275	16.6250	269.875	10.6250	269.875	10.6250	3.2	1.6	2 930	7 450	LM258649D/610/610D 47T644533L	1	341	407	392	8.5	3.2	1.6	0.32	2.12	3.15	2.07	104
	12.5000	447.675	17.6250	327.025	12.8750	327.025	12.8750	6.4	1.6	4 280	10 100		1	344	426	411	11.5	6.4	1.6	0.33	2.03	3.02	1.98	161
320	—	460	—	325	—	325	—	4	2.5	4 030	9 420	47T644633 37264 47T644825	1	349	442	424	10	3	2.5	0.42	1.62	2.42	1.59	175
	—	460	—	338	—	338	—	4	5	3 500	8 590		1	356	442	421	8.5	3	4	0.33	2.03	3.02	1.98	183
	—	480	—	254	—	254	—	4	2.5	3 400	6 940		1-P	358	462	437	9	3	2	0.40	1.68	2.50	1.64	161
337.375	13.2825	469.900	18.5000	342.900	13.5000	342.900	13.5000	3.2	1.6	4 630	11 400	HM261049D/010/010D	1-P	360	455	432	9	3.2	1.6	0.33	2.02	3.01	1.97	190
340	—	480	—	350	—	350	—	5	6	4 700	11 700	37268A	1-P	371	458	443	9.5	4	6	0.33	2.03	3.02	1.98	198
343.052	13.5060	457.098	17.9960	254.000	10.0000	254.000	10.0000	3.2	1.6	2 850	6 950	47T694625	1	363	442	425	6	3.2	1.6	0.47	1.43	2.12	1.40	111
346.075	13.6250	488.950	19.2500	358.775	14.1250	358.775	14.1250	3.2	3.2	4 620	11 600	HM262749D/10/10D	1	378	474	449	8	3.2	3.2	0.33	2.02	3.00	1.97	214
355.600	14.0000	482.600	19.0000	269.875	10.6250	265.112	10.4375	3.2	1.6	3 060	7 020	LM763449D/410/410D 47T714827-1 M263349D/310/310D	1	381	468	450	3.5	3.2	1.6	0.47	1.43	2.14	1.40	136
	14.0000	482.600	19.0000	269.875	10.6250	265.113	10.4375	3.2	1.6	3 390	7 860		1	386	468	450	8	3.2	1.6	0.26	2.55	3.80	2.50	139
	14.0000	488.950	19.2500	317.500	12.5000	317.500	12.5000	3.2	1.6	4 370	10 900		1-P	383	474	452	7.5	3.2	1.6	0.33	2.03	3.02	1.98	182
360	—	508	—	370	—	370	—	5	6	4 840	11 500	47T725137	1	392	486	471	7	4	6	0.33	2.03	3.02	1.98	232
368.300	14.5000	523.875	20.6250	382.588	15.0625	382.588	15.0625	6.4	3.2	5 920	14 500	47T745238J	1-P	401	502	485	10.5	6.4	3.2	0.33	2.03	3.02	1.98	268
380	—	536	—	390	—	390	—	5	6	5 760	12 900	37276	1	415	514	496	7.5	4	5	0.40	1.68	2.50	1.64	268

[Note] 1) While metric series bearings have minus tolerances for bore and OD, inch series have plus tolerances. Refer to page 47 for details of applicable tolerance standards.

Four-row tapered roller bearings ... TQO type

d (380) ~ 490 mm

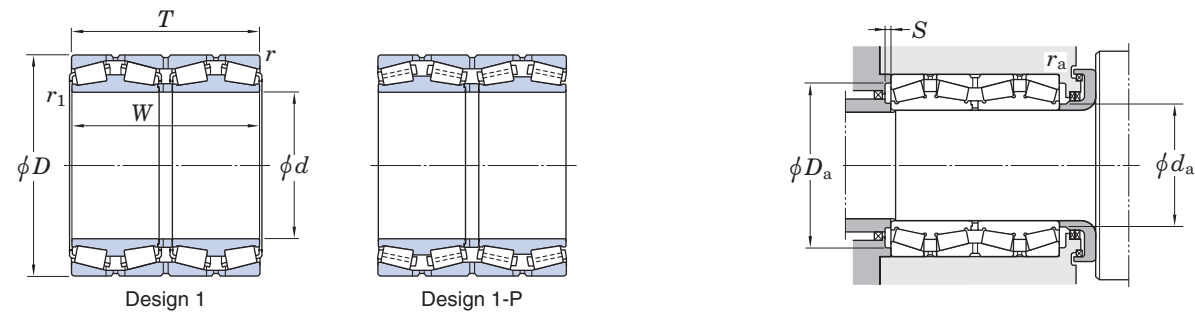

		Boundary dimensions								Basic load ratings (kN)		Bearing No. ¹⁾	De-sign	Mounting dimensions (mm)						Con-stant e	Axial load factors			(Refer.) Mass (kg)
d	D	T	W	r	r_1	C_r	C_{0r}	d_a	D_a	S	r_a			r_b	Y_2	Y_3	Y_0							
mm	inch	mm	inch	mm	inch	mm	inch	min.	min.			max.	max.	min.	min.	max.	max.							
380	—	560	—	285	—	285	—	4	5	4 600	10 000	47T765629	1-P	428	542	513	11	3	4	0.27	2.47	3.67	2.41	246
384.175	15.1250	546.100	21.5000	470.000	18.5039	470.000	18.5039	6.4	3.2	6 220	16 200	47T775547	1	418	524	503	7.5	6.4	3.2	0.33	2.03	3.02	1.98	360
390	—	510	—	350	—	350	—	3	1.5	4 300	11 700	47T785135A	1	413	496	478	10.5	2.5	1.5	0.33	2.03	3.02	1.98	186
400	—	560	—	380	—	380	—	4	1.5	5 970	15 200	47T805638A	1-P	435	542	519	10	3	1.5	0.33	2.03	3.02	1.98	296
	—	590	—	304	—	304	—	4	1.5	4 760	10 200	47T805930A	1-P	449	572	540	7.5	3	1.5	0.33	2.03	3.02	1.98	289
406.400	16.0000	562.000	22.1260	381.000	15.0000	381.000	15.0000	6.4	3.2	5 990	15 000	47T815638	1	439	540	524	9.5	6.4	3.2	0.33	2.03	3.02	1.98	284
415.925	16.3750	590.550	23.2500	434.975	17.1250	434.975	17.1250	6.4	3.2	7 060	18 800	47T835943A	1-P	455	568	543	10	6.4	3.2	0.33	2.03	3.02	1.98	391
420	—	592	—	432	—	432	—	5	6	6 030	15 700	37284	1	460	570	544	7.5	4	5	0.33	2.03	3.02	1.98	374
431.800	17.0000	571.500	22.5000	336.550	13.2500	336.550	13.2500	6.4	1.6	5 070	13 500	47T865734	1-P	460	549	534	10	6.4	1.6	0.36	1.87	2.79	1.83	232
440	—	580	—	420	—	420	—	4	1.5	5 730	15 400	47T885842	1-P	467	562	544	1.5	3	1.5	0.26	2.55	3.80	2.50	288
	—	620	—	454	—	454	—	6	6	7 110	17 500	37288	1	482	592	576	9	5	5	0.40	1.68	2.50	1.64	417
	—	620	—	454	—	454	—	4	5	7 610	19 800	47T886246	1-P	474	602	573	10.5	3	5	0.40	1.68	2.50	1.64	436
449.949	17.7145	594.949	23.4232	368.000	14.4882	368.000	14.4882	5	2.5	5 980	16 200	M270449D/10/10D	1-P	478	573	557	9	5	2	0.33	2.03	3.02	1.98	278
450	—	580	—	450	—	450	—	6	1.5	5 130	14 600	47T905845	1	475	552	537	2	5	1.5	0.26	2.55	3.80	2.50	286
457.200	18.0000	596.900	23.5000	279.400	11.0000	276.225	10.8750	3.2	1.6	4 260	11 400	47T916028A	1-P	485	581	560	8.5	3.2	1.6	0.47	1.43	2.12	1.40	307
460	—	586	—	280	—	280	—	3	1	3 710	9 810	47T925928	1	483	572	555	10.5	2.5	1	0.44	1.52	2.26	1.49	177
	—	615	—	360	—	360	—	3	1	5 000	13 300	47T926236	1	490	601	572	8	2.5	1	0.47	1.43	2.12	1.40	292
475.000	18.7008	600.000	23.6220	368.000	14.4882	368.000	14.4882	4.8	1.6	4 970	15 100	47T956037A	1	501	581	566	10.5	4.8	1.6	0.26	2.55	3.80	2.50	246
479.425	18.8750	679.450	26.7500	495.300	19.5000	495.300	19.5000	6.4	3.2	9 660	25 400	47T966850	1-P	523	656	641	12.5	6.4	3.2	0.33	2.03	3.02	1.98	591
480	—	678	—	494	—	494	—	6	6	9 160	23 300	37296	1-P	520	650	629	9.5	5	5	0.33	2.03	3.02	1.98	563
482.600	19.0000	615.950	24.2500	330.200	13.0000	330.200	13.0000	6.4	4.8	5 270	15 000	4TR19B	1-P	509	593	573	10.5	6.4	4.8	0.33	2.03	3.02	1.98	243
	19.0000	615.950	24.2500	330.200	13.0000	330.200	13.0000	6.4	3.2	5 210	15 000	4TR19D	1	508	593	573	10	6.4	3.2	0.36	1.87	2.79	1.83	240
	19.0000	615.950	24.2500	420.000	16.5354	420.000	16.5354	4	2.5	5 810	16 700	47T976242	1	508	597	577	6	4	2.5	0.26	2.55	3.80	2.50	296
489.026	19.2530	634.873	24.9950	320.675	12.6250	320.675	12.6250	3.2	3.2	4 930	13 700	LM772749D/710/710D	1	513	618	594	9.5	3.2	3.2	0.47	1.43	2.12	1.40	261
490	—	625	—	385	—	385	—	4	1.5	5 540	16 600	47T986339B	1	517	607	587	4.5	3	1.5	0.32	2.12	3.15	2.07	285

[Note] 1) While metric series bearings have minus tolerances for bore and OD, inch series have plus tolerances. Refer to page 47 for details of applicable tolerance standards.

Four-row tapered roller bearings ... TQO type

d 500 ~ 708.025 mm

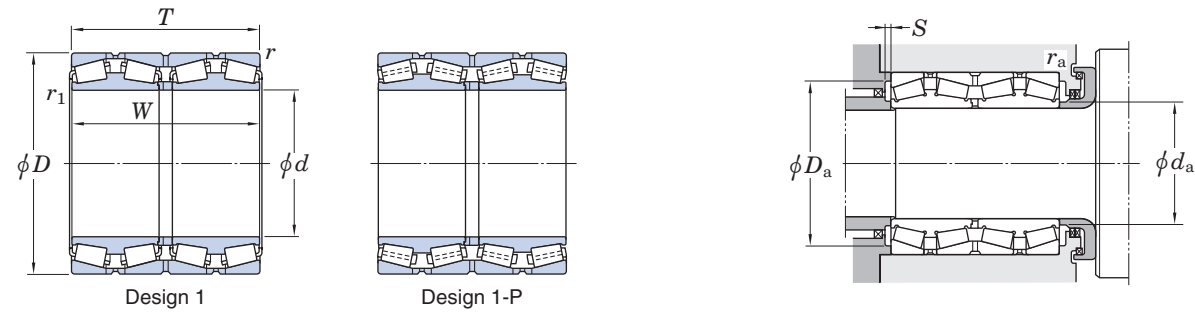

Boundary dimensions										Basic load ratings (kN)		Bearing No. ¹⁾	De- sign	Mounting dimensions (mm)						Con- stant e	Axial load factors			(Refer.) Mass (kg)
d	D	T	W	r	$r_1^{2)}$	C_r	C_{0r}	d_a	D_a	S	r_a			r_b	Y_2	Y_3	Y_0							
mm	inch	mm	inch	mm	inch	mm	inch	min.	min.			max.	max.	min.	min.	max.	max.							
500	—	670	—	515	—	515	—	5	6	9 110	25 700	4TR500B 372/500	1-P	530	648	626	11	4	5	0.32	2.12	3.15	2.07	510
	—	705	—	515	—	515	—	6	SP	9 530	24 500		1-P	544	677	651	8.5	5	6	0.37	1.80	2.69	1.76	641
509.948	20.0767	654.924	25.7844	379.000	14.9213	377.000	14.8425	6.4	1.6	5 780	16 700	4TR510A	1-P	534	632	612	7	6.4	1.6	0.41	1.64	2.44	1.60	315
510	—	655	—	379	—	377	—	5	2.5	6 540	18 600	4TR510L	1-P	540	633	613	9	4	2.5	0.26	2.55	3.80	2.50	320
514.350	20.2500	673.100	26.5000	422.275	16.6250	422.275	16.6250	6.4	3.2	7 190	20 100	4TR514A	1	545	650	630	11	6.4	3.2	0.33	2.03	3.02	1.98	392
519.113	20.4375	736.600	29.0000	536.575	21.1250	536.575	21.1250	6.4	3.2	10 600	27 200	M275349D/310/310D	1-P	562	712	681	10.5	6.4	3.2	0.33	2.03	3.02	1.98	743
536.575	21.1250	761.873	29.9950	558.800	22.0000	558.800	22.0000	6.4	3.2	11 300	28 800	M276449D/410/410D	1-P	578	738	700	9	6.4	3.2	0.33	2.03	3.02	1.98	820
558.800	22.0000	736.600	29.0000	322.263	12.6875	322.263	12.6875	6.4	3.2	5 920	16 100	EE843221D/290/291D	1-P	607	712	692	9.5	6.4	3.2	0.34	1.97	2.93	1.93	371
	22.0000	736.600	29.0000	409.575	16.1250	409.575	16.1250	6.4	3.2	7 660	21 500	4TR559N	1-P	594	712	689	10.5	6.4	3.2	0.35	1.95	2.90	1.91	477
	22.0000	736.600	29.0000	450.000	17.7165	450.000	17.7165	4	3	8 220	23 100	4TR559A	1-P	594	717	692	9	4	3	0.35	1.95	2.90	1.91	525
570	—	780	—	515	—	515	—	5	2.5	10 100	27 400	4TR570A	1-P	618	758	726	10	4	2	0.42	1.61	2.39	1.57	737
571.500	22.5000	812.800	32.0000	593.725	23.3750	593.725	23.3750	6.4	3.2	13 000	35 000	M278749D/710/710D	1-P	625	789	751	14	6.4	3.2	0.33	2.03	3.02	1.98	1 020
584.200	23.0000	730.250	28.7500	349.250	13.7500	342.900	13.5000	3.2	1.6	5 580	17 300	4TR584	1-P	613	712	692	6.5	3.2	1.6	0.43	1.57	2.34	1.53	326
	23.0000	762.000	30.0000	401.638	15.8125	396.875	15.6250	6.4	3.2	7 330	20 800	LM778549D/510/510D	1-P	617	738	715	8.5	6.4	3.2	0.47	1.43	2.12	1.40	468
595.312	23.4375	844.550	33.2500	615.950	24.2500	615.950	24.2500	6.4	3.2	13 600	36 900	M280049D/010/010D	1-P	651	820	780	8	6.4	3.2	0.33	2.03	3.02	1.98	1 130
600	—	855	—	620	—	620	—	5	6	14 000	37 900	4TR600B	1-P	658	833	792	13	4	5	0.33	2.03	3.02	1.98	1 160
603.250	23.7500	857.250	33.7500	622.300	24.5000	622.300	24.5000	6.4	3.2	14 500	38 500	M280249D/210/210XD	1-P	652	833	788	12	6.4	3.2	0.33	2.03	3.02	1.98	1 170
609.600	24.0000	787.400	31.0000	361.950	14.2500	361.950	14.2500	6.4	3.2	6 790	19 900	EE649241D/310/311D	1-P	650	763	739	13	6.4	3.2	0.37	1.82	2.70	1.78	459
630	—	920	—	457.15	—	457.15	—	6	3	11 500	26 200	4TR630B	1-P	698	892	846	11.5	5	2.5	0.33	2.03	3.02	1.98	1 050
646.112	25.4375	857.250	33.7500	542.925	21.3750	542.925	21.3750	6.4	3.2	11 400	34 100	LM281049D/10/10D	1-P	690	833	801	13	6.4	3.2	0.33	2.03	3.02	1.98	881
657.225	25.8750	933.450	36.7500	676.275	26.6250	676.275	26.6250	6.4	3.3	17 300	46 000	M281649D/610/610D	1-P	713	909	864	9.5	6.4	3.3	0.33	2.03	3.02	1.98	1 530
670	—	960	—	700	—	700	—	7.5	5	17 800	48 100	4TR670	1-P	732	924	884	13	6	4	0.33	2.03	3.02	1.98	1 710
679.450	26.7500	901.700	35.5000	552.450	21.7500	552.450	21.7500	6.4	3.2	12 800	36 100	LM281849D/810/810D	1-P	724	877	847	11.5	6.4	3.2	0.33	2.03	3.02	1.98	973
685.800	27.0000	876.300	34.5000	355.600	14.0000	352.425	13.8750	6.4	3.2	7 390	23 100	4TR686A	1-P	734	852	824	11	6.4	3.2	0.42	1.62	2.42	1.59	554
708.025	27.8750	930.275	36.6250	565.150	22.2500	565.150	22.2500	6.4	3.2	13 800	40 300	4TR708B	1-P	753	906	878	11	6.4	3.2	0.33	2.03	3.02	1.98	1 050

[Notes] 1) While metric series bearings have minus tolerances for bore and OD, inch series have plus tolerances. Refer to page 47 for details of applicable tolerance standards.

2) SP indicates the specially chamfered form.

Four-row tapered roller bearings ... TQO type

d 710.000 ~ 939.800 mm

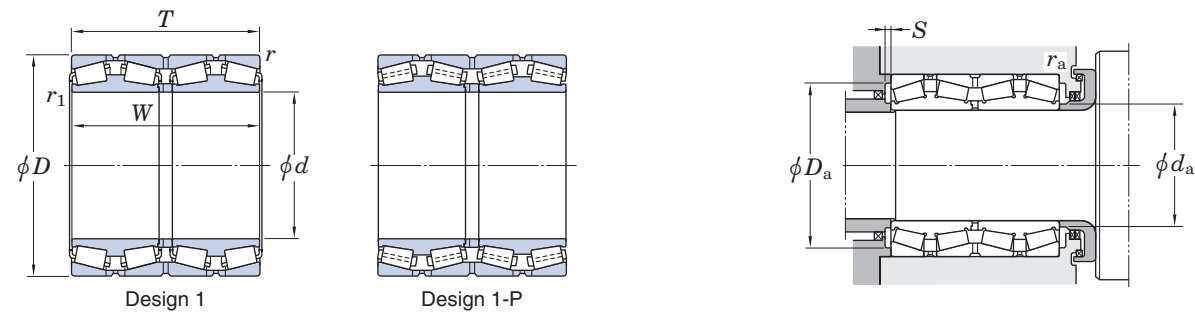

Boundary dimensions										Basic load ratings (kN)		Bearing No. ¹⁾	De-sign	Mounting dimensions (mm)						Con-stant e	Axial load factors			(Refer.) Mass (kg)
d		D		T		W		r min.	r_1 min.	C_r	C_{0r}			d_a max.	d_a max.	D_a min.	S min.	r_a max.	r_b max.		Y_2	Y_3	Y_0	
710.000	27.9528	900.000	35.4331	410.000	16.1417	410.000	16.1417	6	3	9 190	27 300	4TR710	1-P	750	877	853	11.5	6	2.5	0.35	1.95	2.90	1.91	636
711.200	28.0000	914.400	36.0000	317.500	12.5000	317.500	12.5000	6.4	6.4	6 810	18 800	4TR711 47T1429136	1-P	774	890	868	11.5	6.4	6.4	0.38	1.78	2.65	1.74	538
	28.0000	914.400	36.0000	355.600	14.0000	355.600	14.0000	6.4	3.2	7 850	21 200		1-P	753	890	860	10.5	6.4	3.2	0.38	1.78	2.65	1.74	598
717.550	28.2500	946.150	37.2500	565.150	22.2500	565.150	22.2500	6.4	3.2	13 600	39 500	LM282847D/810/810D	1-P	764	922	890	12.5	6.4	3.2	0.33	2.03	3.02	1.98	1 090
749.300	29.5000	990.600	39.0000	605.000	23.8189	605.000	23.8189	6.4	3.2	15 700	47 700	LM283649D/610/610D	1-P	801	966	929	13	6.4	3.2	0.32	2.12	3.15	2.07	1 320
750.000	29.5276	950.000	37.4016	410.000	16.1417	410.000	16.1417	4	2.5	9 700	29 000	4TR750	1-P	791	929	900	11.5	4	2	0.40	1.68	2.50	1.68	705
762.000	30.0000	1 079.500	42.5000	787.400	31.0000	787.400	31.0000	12.7	4.8	22 200	62 700	M284249D/210/210XD	1-P	831	1 043	998	11	12.7	4.8	0.33	2.03	3.02	1.98	2 360
825.500	32.5000	1 168.400	46.0000	844.550	33.2500	844.550	33.2500	12.7	4.8	26 000	72 300	M285848D/10/10D	1-P	897	1 132	1 083	15.5	12.7	4.8	0.33	2.03	3.02	1.98	2 980
	34.0000	1 130.300	44.5000	669.925	26.3750	669.925	26.3750	12.7	4.8	19 100	59 600		1-P	920	1 093	1 063	15	12.7	4.8	0.32	2.08	3.10	2.04	1 840
863.600	34.0000	1 219.200	48.0000	889.000	35.0000	876.300	34.5000	12.7	4.8	28 500	84 600	EE547341D/480/481D	1-P	947	1 182	1 130	9	12.7	4.8	0.33	2.03	3.02	1.98	3 390
938.213	36.9375	1 270.000	50.0000	825.500	32.5000	825.500	32.5000	12.7	4.8	26 800	79 800	LM287649D/610/610D	1-P	1 007	1 233	1 187	17.5	12.7	4.8	0.33	2.03	3.02	1.98	3 130
939.800	37.0000	1 333.500	52.5000	952.500	37.5000	952.500	37.5000	12.7	4.8	33 500	95 400	LM287849D/810/810D	1-P	1 022	1 297	1 235	15.5	12.7	4.8	0.33	2.03	3.02	1.98	4 380

[Note] 1) While metric series bearings have minus tolerances for bore and OD, inch series have plus tolerances. Refer to page 47 for details of applicable tolerance standards.

Four-row cylindrical roller bearings

d 180 ~ 560 mm

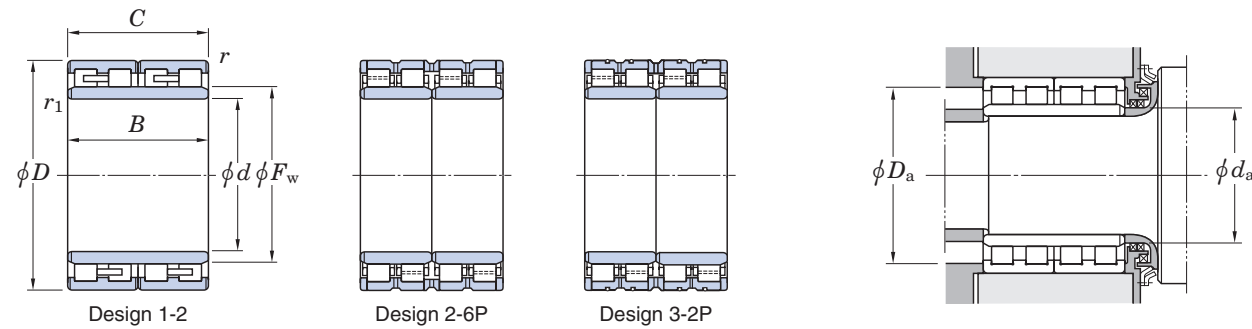

d	Boundary dimensions (mm)						Basic load ratings (kN)		Bearing No.	Design	Mounting dimensions (mm)					(Refer.) Mass (kg)
	D	B	C	F_w	r min.	r_1 ¹⁾ min.	C_r	C_{0r}			d_a min.	D_a max.	r_a ²⁾ min.	r_a ²⁾ max.	r_b ²⁾ min.	
180	250	156	156	200	2	2	1 020	2 130	36FC25156A	1-2	190	240	234	2	2	23.3
	260	168	168	202	2.1	2.1	1 230	2 420	36FC26168	1-2	192	248	242	2	2	29.3
190	260	168	168	212	2.1	2.1	1 140	2 600	38FC26168-1	1-2	202	248	244	2	2	26.5
200	280	200	200	222	2	2	1 450	3 090	313893-1	1-2	210	270	262	2	2	37.7
	290	192	192	226	2.1	2.1	1 460	3 030	313811	1-2	212	278	268	2	2	42.0
220	310	192	192	247	2.1	2.1	1 520	3 270	313837-1	1-2	232	298	289	2	2	45.5
	310	192	192	246	2	2	1 630	3 420	313837A	1-2	230	300	291	2	2	44.9
230	330	206	206	260	2.1	2.1	1 880	3 980	313824A	1-2	242	318	308	2	2	57.5
240	330	220	220	264	2.1	2.1	1 830	4 120	48FC33220	1-2	252	318	308	2	2	54.3
	340	220	220	268	3	3	2 000	4 240	48FC34220	1-2	254	326	318	2.5	2.5	63.4
260	370	220	220	292	3	3	2 000	4 330	313823	1-2	274	356	342	2.5	2.5	76.0
	370	220	220	290	3	3	2 180	4 480	313823A	1-2	274	356	346	2.5	2.5	75.0
280	390	220	220	312	3	3	2 320	5 100	313822D	1-2	294	376	366	2.5	2.5	80.1
300	420	300	300	332	2	2	3 750	8 690	60FC42300L-2	2-6P	310	410	395	2	2	129
330	460	340	340	364	2.1	2.1	3 860	9 150	66FC46340	1-2	342	448	428	2	2	172
340	480	385	350	378	2.1	SP	4 780	11 500	68FC48350N	2-6P	358	468	448	2	3	209
380	540	400	380	422	4	4	6 010	14 300	76FC54380	2-6P	398	522	504	3	3	287
	540	400	400	422	4	4	6 040	14 600	76FC54400DW	3-2P	398	522	502	3	3	298
400	560	410	410	445	2	5	6 470	16 300	80FC56410	2-6P	422	550	525	2	4	315
440	620	450	450	487	4	4	7 900	20 000	88FC62450AW	2-6P	458	602	577	3	3	440
480	680	500	500	534	5	5	8 620	22 000	4CR480B	3-2P	502	658	630	4	4	580
	680	500	500	532	5	5	9 550	24 300	96FC68500A	2-6P	502	658	632	4	4	595
500	670	450	450	540	5	SP	8 460	22 500	100FC67450A-3	2-6P	522	648	630	4	4	451
	680	450	450	542.5	4	4	8 980	23 100	100FC68450	2-6P	518	662	639	3	3	495
	720	530	530	568	5	4	11 000	28 900	100FC72530C	2-6P	518	698	672	4	3	742
550	740	510	510	600	6	6	10 400	28 100	110FC74510	2-6P	578	712	700	5	5	635
560	820	600	600	625	6	6	14 600	36 300	112FC82600	2-6P	588	792	759	5	5	1 120

[Notes] 1) SP indicates the specially chamfered form.

2) r_a indicates housing chamfer dimension corresponding to outer ring chamfer dimension r . r_b indicates the shaft chamfer dimension corresponding to inner ring chamfer dimension r_1 .

Four-row cylindrical roller bearings

d 600 ~ 920 mm

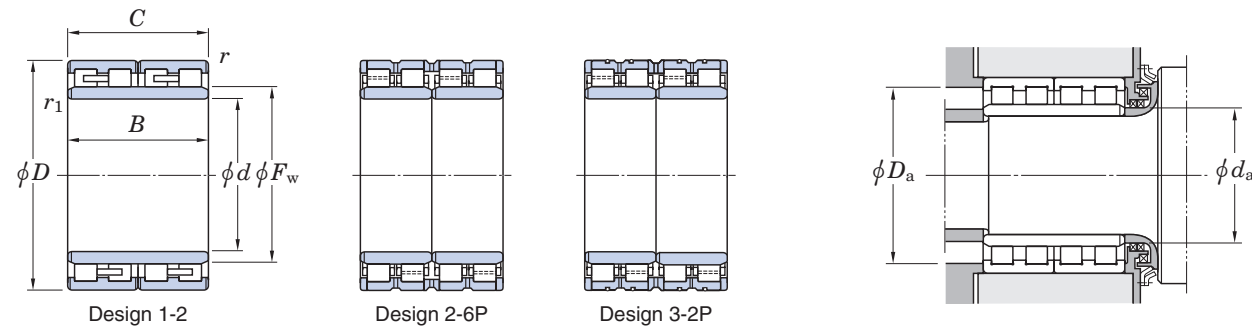

d	Boundary dimensions (mm)						Basic load ratings (kN)		Bearing No.	Design	Mounting dimensions (mm)					(Refer.) Mass (kg)
	D	B	C	F_w	r min.	$r_1^{1)}$ min.	C_r	C_{0r}			d_a min.	D_a max.	$r_a^{2)}$ min.	$r_a^{2)}$ max.	$r_b^{2)}$ min.	
600	820	575	575	660	5	5	13 000	36 000	120FC82575B	2-6P	622	798	772	4	4	925
	850	600	600	664	4	4	14 600	38 100	120FC85600	3-2P	618	832	792	3	3	1 120
	870	640	640	682	4	4	15 500	40 800	4CR600A	2-6P	618	852	812	3	3	1 330
650	920	670	670	723	7.5	7.5	16 700	45 500	130FC92670	2-6P	686	884	855	6	6	1 450
665	968.6	732	732	734.5	6	SP	21 200	53 300	133FC97732	2-6P	693	940	899	5	5	1 870
690	980	750	750	766	6	7.5	19 300	52 300	138FC98750A	2-6P	726	952	910	5	6	1 860
700	980	700	700	774	6	6	17 800	48 200	140FC98700A	3-2P	728	952	914	5	5	1 680
	980	700	700	766	4	4	19 300	51 300	140FC98700C	2-6P	718	962	914	3	3	1 710
730	1 030	750	750	809	6	6	21 600	59 500	146FC103750	2-6P	758	1 002	961	5	5	2 060
750	1 000	670	670	813	6	6	18 300	54 200	150FC100670	2-6P	778	972	941	5	5	1 520
755	1 070	750	750	837	7.5	7.5	22 300	60 300	151FC107750A	3-2P	791	1 034	997	6	6	2 240
760	1 079.5	787	787	846	7.5	7.5	23 800	65 700	152FC108787D	3-2P	796	1 043	1 006	6	6	2 420
761.425	1 079.602	787.4	787.4	846	7.5	7.5	23 800	65 700	152FC108787C	2-6P	798	1 043	1 006	6	6	2 420
765	1 065	662	652	840	6	6	19 200	51 700	153FC107652	2-6P	793	1 037	992	5	5	1 870
770	1 075	770	770	847	7.5	6	23 100	63 500	154FC108770A	2-6P	798	1 039	1 007	6	5	2 250
780	1 070	780	780	852	6	6	22 800	65 100	156FC107780A	2-6P	808	1 042	1 002	5	5	2 140
820	1 130	800	800	903	7.5	7.5	23 400	66 900	164FC113800D	2-6P	856	1 094	1 059	6	6	2 510
850	1 180	850	850	940	7.5	7.5	25 400	72 700	170FC118850B	2-6P	886	1 144	1 104	6	6	2 900
855	1 178	714	704	928.5	6	6	23 600	62 900	171FC118704	2-6P	883	1 150	1 104	5	5	2 410
860	1 160	780	780	932	6	6	24 800	72 600	172FC116780	2-6P	888	1 132	1 088	5	5	2 470
870	1 145	705	685	940	6	6	21 500	63 700	174FC115685B	2-6P	898	1 117	1 085	5	5	1 980
	1 181.1	750	750	942	9.5	SP	24 600	68 600	174FC118750	3-2P	906	1 137	1 110	8	6	2 470
880	1 230	850	850	970	7.5	7.5	29 000	82 100	176FC123850A	2-6P	916	1 194	1 148	6	6	3 280
900	1 220	840	840	989	7.5	7.5	27 600	83 300	180FC122840A	2-6P	936	1 184	1 150	6	6	2 980
920	1 280	815	800	1 010	7.5	7.5	28 700	79 900	184FC128800	3-2P	956	1 244	1 196	6	6	3 280

[Notes] 1) SP indicates the specially chamfered form.

2) r_a indicates housing chamfer dimension corresponding to outer ring chamfer dimension r . r_b indicates the shaft chamfer dimension corresponding to inner ring chamfer dimension r_1 .

Four-row cylindrical roller bearings

d 950 ~ 1 349.04 mm

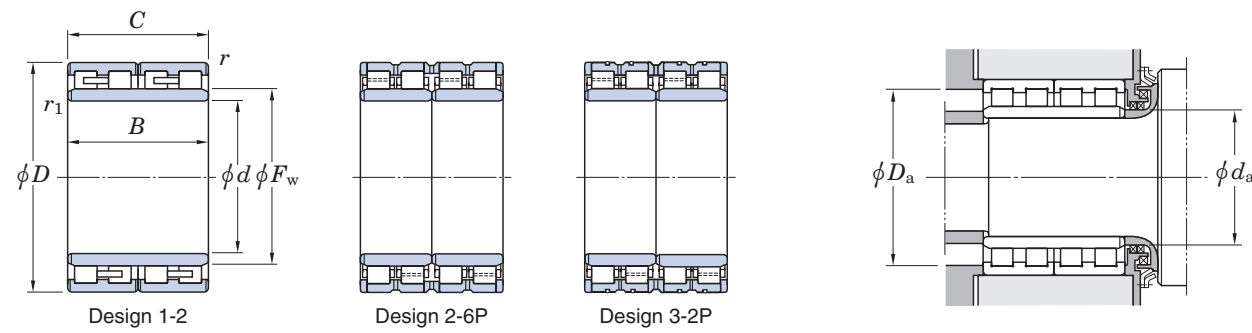

d	Boundary dimensions (mm)						Basic load ratings (kN)		Bearing No.	Design	Mounting dimensions (mm)					(Refer.) Mass (kg)
	D	B	C	F_w	r min.	r_1 min.	C_r	C_{0r}			d_a min.	D_a max.	$r_a^{1)}$ min.	$r_a^{1)}$ max.	$r_b^{1)}$ max.	
950	1 330	950	950	1 053	9.5	9.5	33 300	97 200	190FC133950	2-6P	994	1 286	1 241	8	8	4 330
1 000	1 360	1 025	1 000	1 092	7.5	7.5	36 100	111 000	200FC136100	2-6P	1 036	1 324	1 276	6	6	4 480
1 300	1 655	890	880	1 391	7.5	7.5	36 000	121 000	260FC165880	2-6P	1 336	1 619	1 571	6	6	4 830
1 349.04	1 745	1 010	1 000	1 446	7.5	7.5	44 200	146 000	270FC175110	2-6P	1 386	1 709	1 651	6	6	6 450

[Note] 1) r_a indicates housing chamfer dimension corresponding to outer ring chamfer dimension r .
 r_b indicates the shaft chamfer dimension corresponding to inner ring chamfer dimension r_1 .

Double-row tapered roller bearings for axial support ... TDIS type

d 200 ~ 510 mm



d	Boundary dimensions (mm)					Basic load ratings (kN)				Bearing No. ¹⁾	De- sign	Con- stant e	Axial load factors			Face key way					Mounting dimensions (mm)					Mass (kg)	
	D	B	T	$r^{3)}$ min.	$r_1^{3)}$ min.	C_r	C_{0r}	C_r	C_{0r}				Y_2	Y_3	Y_0	Type	K_w (mm)	K_D (mm)	θ (deg)	qty×Position ²⁾	d_a max.	D_a max.	D_a min.	S_a min.	r_a max.		r_b max.
200	380	180	180	4	SP	1 780	3 240	1 410	3 900	45T403818	2-P	0.8	0.85	1.26	0.83	B	30	25	45	1×2	236	328	294	5.5	3	3	94
260	459	155	155	4	5	1 570	2 780	1 360	3 650	45T524616	2-P	0.87	0.78	1.16	0.76	A	32.1	15	—	2×2	292	400	370	5.5	3	4	95
300	440	105	105	4	4	1 070	2 300	922	3 030	45T604411M	1-P	0.87	0.78	1.16	0.76	B	32.1	22.225	45	1×2	324	398	378	7.5	3	3	50
305	480	200	200	4	SP	2 060	4 670	1 780	6 140	45T614820-1	2	0.87	0.78	1.16	0.76	B	40	28	45	1×2	337	420	377	—	3	2.5	136
	500	200	200	5	6	2 320	4 720	1 770	5 490	45T615020-1	1-P	0.76	0.88	1.31	0.86	B	50.9	35	45	2×2	339	441	400	—	4	5	150
	560	200	200	20	6.5	2 170	4 370	2 360	7 160	45T615620D	1	1.09	0.62	0.92	0.61	A	50.8	19.05	—	2×2	373	482	436	—	10	5	146
320	480	160	160	2.5	SP	1 630	4 090	1 400	5 380	45T644816A	1	0.87	0.78	1.16	0.76	B	51.3	22	45	2×1	349	419	386	5	2	2.5	101
340	590	192	192	SP	SP	2 940	5 870	2 040	6 240	45T685919-1	1-P	0.7	0.97	1.44	0.94	B	50	30	45	1×2	392	518	488	10	1	4	209
345	550	200	270	6	4	2 430	5 740	2 090	7 550	45T695520	1	0.87	0.78	1.16	0.76	A	32	16	—	1×2	373	482	440	2	5	3	176
350	590	192	192	5	SP	2 540	6 570	2 760	10 800	45T705919D	1-P	1.09	0.62	0.92	0.61	A	32	12	—	1×2	401	520	470	11.5	4	5	227
365.6	514.35	140	140	4	SP	1 390	3 730	1 190	4 910	45T735114A	1	0.87	0.78	1.16	0.76	B	40	20	45	2×2	394	457	428	5.5	3	2.5	89
381	695	280	280	6	SP	4 780	9 970	4 120	13 100	45T767028A	2-P	0.87	0.78	1.16	0.76	B	50	45	45	2×2	448	602	547	10	5	5	479
390	548	180	180	4	SP	2 050	5 540	1 770	7 290	45T765518	1	0.87	0.78	1.16	0.76	B	51.3	16	45	1×2	418	495	457	3	3	2.5	169
	562	180	180	4.5	SP	2 110	5 530	1 820	7 280	45T785618	1	0.87	0.78	1.16	0.76	A	32	11.7	—	2×2	420	501	463	4.5	4	2.5	145
400	650	200	200	6	6	2 930	6 500	2 520	8 560	45T806520D	1	0.87	0.78	1.16	0.76	A	50.8	19	—	2×2	465	582	542	4.5	5	5	243
	650	240	240	6	SP	3 770	8 390	3 250	11 000	2TR400L	1-P	0.87	0.78	1.16	0.76	B	64.3	32	45	1×2	437	580	534	5.5	5	2	296
406.4	546.1	138.112	138.112	6.4	SP	1 490	3 920	1 280	5 160	45T815514	1	0.87	0.78	1.16	0.76	A	50	11	—	1×2	436	502	474	5	5	3	89
410	580	160	160	4	7	2 180	5 430	1 880	7 140	45T825816A-1	2	0.87	0.78	1.16	0.76	A	50.8	10	—	1×2	434	532	500	9	3	5	133
440	650	155	155	6	SP	2 220	5 110	1 910	6 720	45T886516A	2-P	0.87	0.78	1.16	0.76	SP	50	15	45	1×2	484	593	564	8	5	4	172
450	830	320	320	7.5	7.5	5 570	10 900	5 800	17 200	45T908332-1	1-P	1.05	0.64	0.96	0.63	B	60	55	45	2×2	501	706	636	1	6	6	691
482	655	160	170	4	4	1 890	5 270	1 630	6 930	45T966616-1	1	0.87	0.78	1.16	0.76	B	40	20	45	2×2	518	590	554	—	3	3	157
482.6	733.5	190	190	SP	SP	3 230	8 000	2 620	9 880	45T977319	1-P	0.81	0.83	1.23	0.81	B	64.2	44.45	45	1×2	547	669	635	7.5	2	2	283
	733.501	200.025	200	17.5	6.4	2 950	7 100	3 200	11 600	45T977320J	1-P	1.09	0.62	0.92	0.61	A	50.8	19.05	—	1×2	513	651	603	5	10	5	280
509.998	733.5	200.02	200.02	5	6	3 230	8 000	2 620	9 880	2TR510L-1	1-P	0.81	0.83	1.23	0.81	B	50.8	38.1	45	2×2	560	667	630	3.5	4	5	261
510	800	285	285	6	SP	5 370	12 300	4 260	14 800	2TR510-2	1-P	0.8	0.85	1.26	0.83	B	70.2	44.45	45	1×2	570	716	662	7	6	6	506

[Notes] 1) Since there are many bearings of special tolerances for specific applications, consult with JTEKT for details of tolerances.

2) [x1]...one face, [x2]...both face.

3) SP indicates the specially chamfered form.

Double-row tapered roller bearings for axial support ... TDIS type

d 635 ~ 717.55 mm

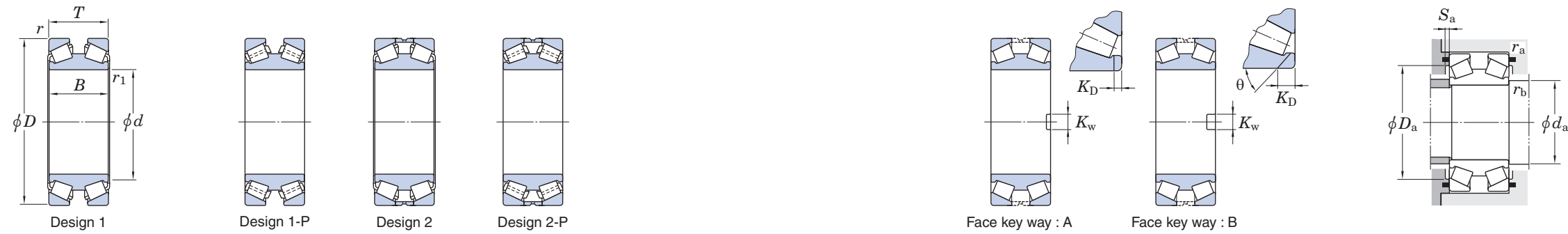

Boundary dimensions (mm)				Basic load ratings (kN)				Bearing No. ¹⁾	De-sign	Con-stant e	Axial load factors			Face key way				Mounting dimensions (mm)					Mass (kg)					
d	D	B	T	r ³⁾ min.	r_1 ³⁾ min.	Radial C_r	C_{0r}				Axial C_r	C_{0r}	Y_2	Y_3	Y_0	Type	K_w (mm)	K_D (mm)	θ (deg)	qty×Position ²⁾	d_a max.	D_a max.		D_a min.	S_a min.	r_a max.	r_b max.	
635	940	260	260	5.4	3.2	4 570	10 600	5 320	19 000	2TR635B-1	1-P	1.17		0.58	0.86	0.56	B	70.3	51	45	1×2	674	852	793	—	5	3	477
685.8	939.8	235	228.6	SP	SP	4 930	12 800	3 760	14 900	2TR686A	1-P	0.76		0.88	1.31	0.86	B	63.6	38.5	45	1×2	730	868	827	8.5	1	3	455
717.55	1 000	200	200	6	SP	4 070	12 400	3 510	16 300	2TR718	1-P	0.87		0.78	1.16	0.76	B	70.3	44.5	45	1×2	800	914	874	9	5	5	482

[Notes] 1) Since there are many bearings of special tolerances for specific applications, consult with JTEKT for details of tolerances.

2) [×1]...one face, [×2]...both face.

3) SP indicates the specially chamfered form.

1. Recommended fits for rolling mill roll neck bearing

A rolling mill roll neck bearing is subject to inner ring rotating load. Its inner ring always receives a load on its entire circumference, and a load is applied to the outer ring at only one location.

Thus, interference fit is required for the inner ring to prevent any creep, and clearance fit should be used for the outer ring, in principle. For easy attachment, clearance fit has been used for roll neck bearings (because recombination and replacement must be frequently done for roll grinding).

However, with more increase in rolling speed and rolling load, interference fit has been more commonly used to

prevent danger of creep to be generated when clearance fit is used and improve in accuracy of products.

Clearance fit is used for the inner rings of deep groove ball bearings and angular ball bearings used as bearings receiving axial load. Between the outer ring and the chock, adequate clearance should be provided in order to prevent any radial load applied to the outer ring.

Tables 1-1 through 1-4 show the recommended fits for roll neck bearings.

When machining a roll neck or chock, its roundness must not exceed 50 % of the allowable tolerances shown in Tables 1-1 through 1-4. If its roundness is poor, fretting corrosion may frequently occur.

Table 1-1 Recommended fits for roll neck metric series four-row tapered roller bearing

Double inner ring and roll neck (shaft)						Outer ring and chock (housing)					
Nominal bore diameter d mm		Single plane mean bore diameter deviation Δ_{dmp} μm		Roll neck diameter deviation μm		Nominal outside diameter D mm		Single plane mean outside diameter deviation Δ_{Dmp} μm		Chock bore diameter deviation μm	
over	up to	upper	lower	upper	lower	over	up to	upper	lower	upper	lower
80	120	0	-20	-120	-150	120	150	0	-20	+57	+25
120	180	0	-25	-150	-175	150	180	0	-25	+100	+50
180	250	0	-30	-175	-200	180	250	0	-30	+120	+50
250	315	0	-35	-210	-250	250	315	0	-35	+115	+50
315	400	0	-40	-240	-300	315	400	0	-40	+110	+50
400	500	0	-45	-245	-300	400	500	0	-45	+105	+50
500	630	0	-50	-250	-300	500	630	0	-50	+100	+50
630	800	0	-75	-325	-400	630	800	0	-75	+150	+75
800	1 000	0	-100	-350	-425	800	1 000	0	-100	+150	+75
1 000	1 250	0	-125	-425	-500	1 000	1 250	0	-125	+175	+100
1 250	1 600	0	-160	-510	-600	1 250	1 600	0	-160	+215	+125
						1 600	2 000	0	-200	+250	+150

Table 1-2 Recommended fits for roll neck inch series four-row tapered roller bearing

Double inner ring and roll neck (shaft)						Outer ring and chock (housing)					
Nominal bore diameter d mm (1/25.4)		Single bore diameter deviation Δ_{ds} μm		Roll neck diameter deviation μm		Nominal outside diameter D mm (1/25.4)		Single outside diameter deviation Δ_{Ds} μm		Chock bore diameter deviation μm	
over	up to	upper	lower	upper	lower	over	up to	upper	lower	upper	lower
76.2 (3.0)	101.6 (4.0)	+25	0	-75	-100	-	304.8 (12.0)	+25	0	+75	+50
101.6 (4.0)	127.0 (5.0)	+25	0	-100	-125	304.8 (12.0)	609.6 (24.0)	+51	0	+150	+100
127.0 (5.0)	152.4 (6.0)	+25	0	-125	-150	609.6 (24.0)	914.4 (36.0)	+76	0	+225	+150
152.4 (6.0)	203.2 (8.0)	+25	0	-150	-175	914.4 (36.0)	1 219.2 (48.0)	+102	0	+300	+200
203.2 (8.0)	304.8 (12.0)	+25	0	-175	-200	1 219.2 (48.0)	1 524.0 (60.0)	+127	0	+375	+250
304.8 (12.0)	609.6 (24.0)	+51	0	-200	-250	1 524.0 (60.0)		+127	0	+450	+300
609.6 (24.0)	914.4 (36.0)	+76	0	-250	-325						
914.4 (36.0)	1 219.2 (48.0)	+102	0	-300	-400						
1 219.2 (48.0)		+127	0	-375	-475						

Table 1-3 Recommended fits for roll neck four-row cylindrical roller bearing (inner ring interference fit)

Inner ring and roll neck (shaft)						Outer ring and chock (housing)					
Nominal bore diameter <i>d</i> mm		Single plane mean bore diameter deviation Δd_{mp} μm		Roll neck diameter deviation μm		Nominal outside diameter <i>D</i> mm		Single plane mean outside diameter deviation ΔD_{mp} μm		Chock bore diameter deviation μm	
over	up to	upper	lower	upper	lower	over	up to	upper	lower	upper	lower
80	120	0	-20	+59	+37 (p6)	120	150	0	-18	+40	0 (H7)
120	180	0	-25	+68	+43 (p6)	150	180	0	-25	+40	0 (H7)
180	250	0	-30	+79	+50 (p6)	180	250	0	-30	+46	0 (H7)
250	280	0	-35	+126	+94 (r6)	250	315	0	-35	+52	0 (H7)
280	315	0	-35	+130	+98 (r6)	315	400	0	-40	+75	+18 (G7)
315	355	0	-40	+144	+108 (r6)						
355	400	0	-40	+150	+114 (r6)	400	500	0	-45	+83	+20 (G7)
400	450	0	-45	+166	+126 (r6)						
450	500	0	-45	+172	+132 (r6)	500	630	0	-50	+92	+22 (G7)
500	560	0	-50	+194	+150 (r6)						
560	630	0	-50	+354	+310 (s6)	630	800	0	-75	+160	+80 (F7)
630	710	0	-75	+390	+340 (s6)						
710	800	0	-75	+430	+380 (s6)	800	1 000	0	-100	+176	+86 (F7)
800	900	0	-100	+486	+430 (s6)						
900	1 000	0	-100	+526	+470 (s6)	1 000	1 250	0	-125	+203	+98 (F7)
1 000	1 120	0	-125	+588	+520 (s6)						
1 120	1 250	0	-125	+646	+580 (s6)	1 250	1 400	0	-160	+235	+110 (F7)
						1 400	1 600	0	-160	+345	+220 (E7)

[Note] The table above shows general values. JTEKT determines recommended fit on a case by case basis according to bearing materials and operating conditions to prevent the inner ring from creeping.

Consult with JTEKT when referring to this table.

Table 1-4 Recommended fits of bearing types for support of axial loading

Bearing type	Inner ring and roll neck (shaft)	Outer ring and chock (housing)	
	Shaft tolerance range class	Mounted to chock	Mounted to sleeve
		Chock bore tolerance range class	Sleeve bore tolerance range class
Double row tapered roller bearing (bearings for support of axial loading) ... TDIS type	e6 or f6	Nominal chock bore (mm) = Outer ring outer dia. + [0.5 to 1.0] H8	G7

[Remark] When installing a sleeve, clearance of 0.5 mm or more should be provided between the outer diameter of the sleeve and the bore of the chock.

2. Tolerances

2-1. Four-row cylindrical roller bearings

[Applicable tolerance for cylindrical roller bearings]

Type of cylindrical roller bearings	Applicable tolerance
Four-row cylindrical bore bearings	Class 0, class 6, class 5 of JIS B 1514
Four-row tapered bore bearings	Class 0, class 6 of JIS B 1514 (Refer to Table 2-2 on page 45)

Table 2-1 Tolerances of roller set bore diameter and roller set outside diameter of interchangeable bearings

Unit : μm

Nominal bore diameter d (mm)		Roller set bore diameter deviation Δ_{Fw}		Roller set outside diameter deviation Δ_{Ew}	
over	up to	upper	lower	upper	lower
50	120	+ 20	0	0	- 20
120	200	+ 25	0	0	- 25
200	250	+ 30	0	0	- 30
250	315	+ 35	0	0	- 35
315	400	+ 40	0	0	- 40
400	500	+ 45	0	0	- 45
500	600	+ 50	0	0	- 50
600	700	+ 55	0	0	- 55
700	800	+ 60	0	0	- 60
800	900	+ 70	0	0	- 70
900	1 000	+ 80	0	0	- 80
1 000	1 250	+ 90	0	0	- 90
1 250	1 600	+100	0	0	-100
1 600	2 000	+120	0	0	-120
2 000	2 500	+150	0	0	-150

[Remark] Interchangeable bearings have an inner ring with rollers that can be matched with the outer ring, or an outer ring with rollers that can be matched with the inner ring, without affecting performance in the bearing that has the same bearing number in one category.

Table 2-2 (1) Radial bearing tolerances (tapered roller bearings excluded) = JIS B 1514-1 =

(1) Inner ring (bore diameter)

Unit : μm

Nominal bore diameter d mm		Single plane mean bore diameter deviation Δ_{dmp}						Single plane bore diameter variation V_{dsp}						Mean bore diameter variation V_{dmp}		
								Diameter series 0, 1			Diameter series 2, 3, 4					
		class 0	class 6		class 5		class 0	class 6	class 5	class 0	class 6	class 5	class 0	class 6	class 5	
over	up to	upper	lower	upper	lower	upper	lower	max.			max.			max.		
120	150	0	-25	0	-18	0	-13	31	23	10	19	14	10	19	14	7
150	180	0	-25	0	-18	0	-13	31	23	10	19	14	10	19	14	7
180	250	0	-30	0	-22	0	-15	38	28	12	23	17	12	23	17	8
250	315	0	-35	0	-25	0	-18	44	31	14	26	19	14	26	19	9
315	400	0	-40	0	-30	0	-23	50	38	18	30	23	18	30	23	12
400	500	0	-45	0	-35	0	-28	56	44	21	34	26	21	34	26	14
500	630	0	-50	0	-40	0	-35	63	50	26	38	30	26	38	30	18
630	800	0	-75	0	-50	0	-45	94	63	34	56	38	34	56	38	23
800	1 000	0	-100	0	-60	0	-60	125	75	45	75	45	45	75	45	30
1 000	1 250	0	-125	0	-75	0	-75	156	94	56	94	56	56	94	56	38
1 250	1 600	0	-160	-	-	-	-	200	-	-	120	-	-	120	-	-
1 600	2 000	0	-200	-	-	-	-	250	-	-	150	-	-	150	-	-

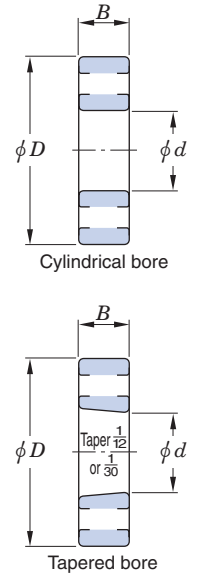

(2) Inner ring (running accuracy and width)

Unit : μm

Nominal bore diameter d mm		Radial runout of assembled bearing inner ring K_{ia}				S_d	Single inner ring width deviation Δ_{Bs}						Single inner ring width deviation $\Delta_{Bs}^{1)}$						Inner ring width variation V_{Bs}			
		class 0		class 6			class 5		class 0		class 6		class 5		class 0 ²⁾		class 6 ²⁾		class 5 ²⁾		class 0	class 6
		over	up to	max.				max.		upper	lower	upper	lower	upper	lower	upper	lower	upper	lower	upper	lower	max.
120	150	30	18	8	10	0	-250	0	-250	0	-250	0	-500	0	-500	0	-380	30	30	8		
150	180	30	18	8	10	0	-250	0	-250	0	-250	0	-500	0	-500	0	-380	30	30	8		
180	250	40	20	10	11	0	-300	0	-300	0	-300	0	-500	0	-500	0	-500	30	30	10		
250	315	50	25	13	13	0	-350	0	-350	0	-350	0	-500	0	-500	0	-500	35	35	13		
315	400	60	30	15	15	0	-400	0	-400	0	-400	0	-630	0	-630	0	-630	40	40	15		
400	500	65	35	20	18	0	-450	0	-450	0	-450	-	-	-	-	-	-	50	45	18		
500	630	70	40	25	25	0	-500	0	-500	0	-500	-	-	-	-	-	-	60	50	20		
630	800	80	50	30	30	0	-750	0	-750	0	-750	-	-	-	-	-	-	70	60	23		
800	1 000	90	60	40	40	0	-1 000	0	-1 000	0	-1 000	-	-	-	-	-	-	80	60	35		
1 000	1 250	100	70	50	50	0	-1 250	0	-1 250	0	-1 250	-	-	-	-	-	-	100	60	45		
1 250	1 600	120	-	-	-	0	-1 600	-	-	-	-	-	-	-	-	-	-	120	-	-		
1 600	2 000	140	-	-	-	0	-2 000	-	-	-	-	-	-	-	-	-	-	140	-	-		

S_d : perpendicularity of inner ring face with respect to the bore

[Notes] 1) These shall be applied to individual bearing rings manufactured for matched pair or stack bearings.

2) Also applicable to the inner ring with tapered bore of $d \geq 50$ mm.

[Remark] Values in Italics are prescribed in JTEKT standards.

Table 2-2 (2) Radial bearing tolerances (tapered roller bearings excluded)

(3) Outer ring (outside diameter)

Unit : μm

Nominal outside dia. D mm		Single plane mean outside diameter deviation ΔD_{mp}						Single plane outside diameter variation $V_{D_{\text{sp}}}$						Mean outside diameter variation $V_{D_{\text{mp}}}$		
								Diameter series 0, 1			Diameter series 2, 3, 4					
		class 0		class 6		class 5		class 0 ¹⁾	class 6 ¹⁾	class 5	class 0 ¹⁾	class 6 ¹⁾	class 5	class 0 ¹⁾	class 6 ¹⁾	class 5
over	up to	upper	lower	upper	lower	upper	lower	max.			max.			max.		
150	180	0	-25	0	-18	0	-13	31	23	10	19	14	10	19	14	7
180	250	0	-30	0	-20	0	-15	38	25	11	23	15	11	23	15	8
250	315	0	-35	0	-25	0	-18	44	31	14	26	19	14	26	19	9
315	400	0	-40	0	-28	0	-20	50	35	15	30	21	15	30	21	10
400	500	0	-45	0	-33	0	-23	56	41	17	34	25	17	34	25	12
500	630	0	-50	0	-38	0	-28	63	48	21	38	29	21	38	29	14
630	800	0	-75	0	-45	0	-35	94	56	26	55	34	26	55	34	18
800	1 000	0	-100	0	-60	0	-50	125	75	38	75	45	38	75	45	25
1 000	1 250	0	-125	0	-75	0	-63	156	94	47	94	56	47	94	56	31
1 250	1 600	0	-160	0	-90	0	-80	200	113	60	120	68	60	120	68	40
1 600	2 000	0	-200	0	-120	-	-	250	150	-	150	90	-	150	90	-
2 000	2 500	0	-250	-	-	-	-	313	-	-	188	-	-	188	-	-

(4) Outer ring (running accuracy and width)

Unit : μm

Nominal outside dia. D mm		Radial runout of assembled bearing outer ring K_{ea}			$S_{\text{D}}^{2)}$	$S_{\text{ea}}^{2)}$
		class 0	class 6	class 5		
		over	up to	max.		
150	180	45	23	13	10	14
180	250	50	25	15	11	15
250	315	60	30	18	13	18
315	400	70	35	20	13	20
400	500	80	40	23	15	23
500	630	100	50	25	18	25
630	800	120	60	30	20	30
800	1 000	140	75	40	23	40
1 000	1 250	160	85	45	30	45
1 250	1 600	190	95	60	45	60
1 600	2 000	220	110	-	-	-
2 000	2 500	250	-	-	-	-

[Notes]

- 1) Shall be applied when locating snap ring is not fitted.
- 2) These shall not be applied to flanged bearings.

[Remark]

Values in Italics are prescribed in JTEKT standards.

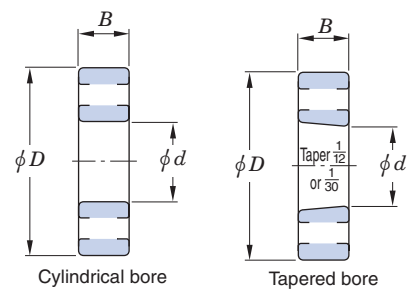

d : nominal bore diameter
 D : nominal outside diameter
 B : nominal assembled bearing width

S_{D} : perpendicularity of outer ring outside surface with respect to the face

S_{ea} : axial runout of assembled bearing outer ring

2-2. Tapered roller bearings

[Applicable tolerance for tapered roller bearings]

Type of tapered roller bearings		Applicable tolerance*
Double-row · Four-row	Metric series	45200, 45300, 46200 (A), 46300 (A) 46T30200JR, 46T32200JR, 46T30300JR, 46T32300JR 37200, 47200, 47300
	Inch series	(LM377449D/LM377410, 67388/67322D) (EE127094D/127138/127139D etc.)
	The others	45T..., 46T..., 47T..., 2TR..., 4TR...

* Consult with JTEKT if a higher tolerance class than that shown in this table is necessary.

Table 2-3 Tolerances for metric series double-row and four-row tapered roller bearings (class 0)
= BAS 1002 =

(1) Inner ring, outer ring width and overall width

Unit : μm

Nominal bore diameter d mm		Single plane mean bore diameter deviation Δ_{dmp}		Single plane bore diameter variation V_{dsp}	Mean bore diameter variation V_{dmp}	K_{ia}	Single outer ring or inner ring width deviation Δ_{Bs}, Δ_{Cs}		Actual overall inner rings/outer rings width deviation			
									Double-row Δ_{Ts}		Four-row Δ_{Ts}, Δ_{Ws}	
over	up to	upper	lower	max.	max.	max.	upper	lower	upper	lower	upper	lower
120	180	0	-25	25	19	35	0	-250	+500	-500	+600	-600
180	250	0	-30	30	23	50	0	-300	+600	-600	+750	-750
250	315	0	-35	35	26	60	0	-350	+700	-700	+900	-900
315	400	0	-40	40	30	70	0	-400	+800	-800	+1000	-1000
400	500	0	-45	45	34	80	0	-450	+900	-900	+1200	-1200
500	630	0	-60	60	40	90	0	-500	+1000	-1000	+1200	-1200
630	800	0	-75	75	45	100	0	-750	+1500	-1500	-	-
800	1000	0	-100	100	55	115	0	-1000	+1500	-1500	-	-

K_{ia} : radial runout of assembled bearing inner ring

(2) Outer ring

Unit : μm

Nominal outside diameter D mm		Single plane mean outside diameter deviation Δ_{Dmp}		Single plane outside diameter variation V_{Dsp}	Mean outside diameter variation V_{Dmp}	K_{ea}
over	up to	upper	lower	max.	max.	max.
150	180	0	-25	25	19	45
180	250	0	-30	30	23	50
250	315	0	-35	35	26	60
315	400	0	-40	40	30	70
400	500	0	-45	45	34	80
500	630	0	-50	60	38	100
630	800	0	-75	80	55	120
800	1000	0	-100	100	75	140
1000	1250	0	-125	130	90	160
1250	1600	0	-160	170	100	180

K_{ea} : radial runout of assembled bearing outer ring

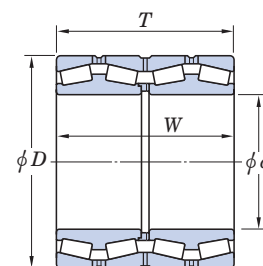
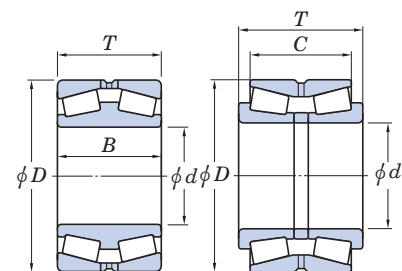

d : nominal bore diameter
 D : nominal outside diameter
 B : nominal double inner ring width
 C : nominal double outer ring width
 T, W : nominal overall width of outer rings (inner rings)

Table 2-4 Tolerances and permissible values for inch series tapered roller bearings = ABMA 19 =

(1) Inner ring

Unit : μm

Applied bearing type	Nominal bore diameter d , mm (1/25.4)		Deviation of a single bore diameter Δ_{ds}							
			Class 4		Class 2		Class 3		Class 0	
	over	up to	upper	lower	upper	lower	upper	lower	upper	lower
All types	–	76.2 (3.0)	+ 13	0	+13	0	+13	0	+13	0
	76.2 (3.0)	266.7 (10.5)	+ 25	0	+25	0	+13	0	+13	0
	266.7 (10.5)	304.8 (12.0)	+ 25	0	+25	0	+13	0	+13	0
	304.8 (12.0)	609.6 (24.0)	+ 51	0	+51	0	+25	0	–	–
	609.6 (24.0)	914.4 (36.0)	+ 76	0	–	–	+38	0	–	–
	914.4 (36.0)	1 219.2 (48.0)	+102	0	–	–	+51	0	–	–
	1 219.2 (48.0)	–	+127	0	–	–	+76	0	–	–

(2) Outer ring

Unit : μm

Applied bearing type	Nominal outside diameter D , mm (1/25.4)		Deviation of a single outside diameter Δ_{Ds}							
			Class 4		Class 2		Class 3		Class 0	
	over	up to	upper	lower	upper	lower	upper	lower	upper	lower
All types	–	266.7 (10.5)	+ 25	0	+25	0	+13	0	+13	0
	266.7 (10.5)	304.8 (12.0)	+ 25	0	+25	0	+13	0	+13	0
	304.8 (12.0)	609.6 (24.0)	+ 51	0	+51	0	+25	0	–	–
	609.6 (24.0)	914.4 (36.0)	+ 76	0	+76	0	+38	0	–	–
	914.4 (36.0)	1 219.2 (48.0)	+102	0	–	–	+51	0	–	–
	1 219.2 (48.0)	–	+127	0	–	–	+76	0	–	–

(3) Radial runout of assembled bearing inner ring/outer ring

Unit : μm

Applied bearing type	Nominal outside diameter D , mm (1/25.4)		Radial runout of inner ring/outer ring K_{ia}, K_{ea}			
			Class 4	Class 2	Class 3	Class 0
	over	up to	max.	max.	max.	max.
All types	–	266.7 (10.5)	51	38	8	4
	266.7 (10.5)	304.8 (12.0)	51	38	8	4
	304.8 (12.0)	609.6 (24.0)	51	38	18	–
	609.6 (24.0)	914.4 (36.0)	76	51	51	–
	914.4 (36.0)	1 219.2 (48.0)	76	–	76	–
	1 219.2 (48.0)	–	76	–	76	–

(4) Assembled bearing width and overall width

Unit : μm

Applied bearing type	Nominal bore diameter d , mm (1/25.4)		Nominal outside diameter D , mm (1/25.4)		Deviation of the actual bearing width and overall width of inner rings/outer rings $\Delta T_s, \Delta W_s$							
	over	up to	over	up to	Class 4		Class 2		Class 3		Class 0	
					upper	lower	upper	lower	upper	lower	upper	lower
Double-row	–	101.6 (4.0)	–	–	+ 406	0	+ 406	0	+ 406	– 406	+ 406	– 406
	101.6 (4.0)	266.7 (10.5)	–	–	+ 711	– 508	+ 406	– 203	+ 406	– 406	+ 406	– 406
	266.7 (10.5)	304.8 (12.0)	–	–	+ 711	– 508	+ 406	– 203	+ 406	– 406	+ 406	– 406
	304.8 (12.0)	609.6 (24.0)	–	508.0 (20.0)	–	–	+ 762	– 762	+ 406	– 406	–	–
	304.8 (12.0)	609.6 (24.0)	508.0 (20.0)	–	–	–	–	+ 762	– 762	+ 762	– 762	–
Double-row (TNA type)	–	127.0 (5.0)	–	–	–	–	+ 254	0	+ 254	0	–	–
	127.0 (5.0)	–	–	–	–	–	+ 762	0	+ 762	0	–	–
Four-row	Total dimensional range		–	–	+1 524	–1 524	+1 524	–1 524	+1 524	–1 524	+1 524	–1 524

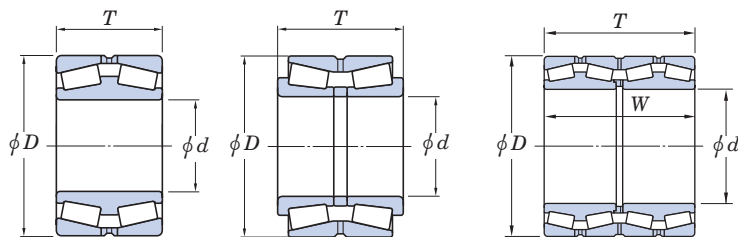

d : nominal bore diameter
 D : nominal outside diameter
 T, W : nominal assembled bearing width and nominal overall width of outer rings (inner rings)

GLOBAL NETWORK

BEARING BUSINESS OPERATIONS

JTEKT CORPORATION NAGOYA HEAD OFFICE

No.7-1, Meieki 4-chome, Nakamura-ku, Nagoya, Aichi 450-8515,
JAPAN
TEL : 81-52-527-1900
FAX : 81-52-527-1911

JTEKT CORPORATION OSAKA HEAD OFFICE

No.5-8, Minamisemba 3-chome, Chuo-ku, Osaka 542-8502,
JAPAN
TEL : 81-6-6271-8451
FAX : 81-6-6245-3712

Sales & Marketing Headquarters

No.5-8, Minamisemba 3-chome, Chuo-ku, Osaka 542-8502,
JAPAN
TEL : 81-6-6245-6087
FAX : 81-6-6244-9007

OFFICES

KOYO CANADA INC.

5324 South Service Road, Burlington, Ontario L7L 5H5, CANADA
TEL : 1-905-681-1121
FAX : 1-905-681-1392

KOYO CORPORATION OF U.S.A.

-Cleveland Office-

29570 Clemens Road, P.O.Box 45028 Westlake,
OH 44145, U.S.A.
TEL : 1-440-835-1000
FAX : 1-440-835-9347

-Detroit Office-

47771 Halyard Drive, Plymouth, MI 48170, U.S.A.
TEL : 1-734-454-1500
FAX : 1-734-454-4076

KOYO MEXICANA, S.A. DE C.V.

Rio Nazas No.171, 3er piso, Col. Cuauhtemoc, México, D.F. C.P.
06500, MEXICO
TEL : 52-55-5207-3860
FAX : 52-55-5207-3873

KOYO LATIN AMERICA, S.A.

Edificio Banco del Pacifico Planta Baja, Calle Aquilino de la
Guardia y Calle 52, Panama, REPUBLICA DE PANAMA
TEL : 507-208-5900
FAX : 507-264-2782/507-269-7578

KOYO ROLAMENTOS DO BRASIL LTDA.

Rua Desembargador Eliseu Ghilherme 304, 7-Andar, Paraiso,
CEP 04004-30, BRASIL
TEL : 55-11-3887-9173
FAX : 55-11-3887-3039

JTEKT (THAILAND) Co., LTD.

172/1 Moo 12 Tambol Bangwua, Amphur Bangpakong,
Chachoengsao 24180, THAILAND
TEL : 66-38-533-310-7
FAX : 66-38-532-776

PT. JTEKT INDONESIA

MM2100 Industrial Town Block DD-3, Cikarang Barat, Bekasi
17520, INDONESIA
TEL : 62-21-8998-3273
FAX : 62-21-8998-3274

KOYO SINGAPORE BEARING (PTE.) LTD.

27, Penjuru Lane, #09-01 C&P Logistics Hub 2, SINGAPORE
609195
TEL : 65-6274-2200
FAX : 65-6862-1623

-MIDDLE EAST (BRANCH)-

6EA312, Dubai Airport Free Zone, P.O. Box 54816, Dubai, U.A.E.
TEL : 971-4-2993600
FAX : 971-4-2993700

PHILIPPINE KOYO BEARING CORPORATION

6th Floor One World Square Building, #10 Upper McKinley Road,
McKinley Town Center, Fort Bonifacio, 1634 Taguig City,
PHILIPPINES
TEL : 63-2-856-5046/5047
FAX : 63-2-856-5045

JTEKT KOREA CO., LTD.

Inwoo Building 6F, 539-11, Shinsa-Dong,
Kangnam-Ku, Seoul, KOREA
TEL : 82-2-549-7922
FAX : 82-2-549-7923

JTEKT (CHINA) CO., LTD.

Rm.1906, Aetna Tower, 107 Zunyi Road, Shanghai, 200051,
CHINA
TEL : 86-21-6237-5280
FAX : 86-21-6237-5277

KOYO (SHANGHAI) CO., LTD.

Rm.1905, Aetna Tower, 107 Zunyi Road, Shanghai, 200051,
CHINA
TEL : 86-21-6237-5280
FAX : 86-21-6237-5277

KOYO AUSTRALIA PTY. LTD.

Unit 2, 8 Hill Road , Homebush Bay, NSW 2127, AUSTRALIA
TEL : 61-2-8719-5300
FAX : 61-2-8719-5333

JTEKT EUROPE BEARINGS B.V.

Markerkant 13-01, 1314 AN Almere, THE NETHERLANDS
TEL : 31-36-5383333
FAX : 31-36-5347212

KOYO KULLAGER SCANDINAVIA A.B.

Johanneslundsvägen 4, 194 61 Upplands Väsby, SWEDEN
TEL : 46-8-594-212-10
FAX : 46-8-594-212-29

KOYO (U.K.) LTD.

Whitehall Avenue, Kingston, Milton Keynes MK10 OAX,
UNITED KINGDOM
TEL : 44-1908-289300
FAX : 44-1908-289333

KOYO ROMANIA REPRESENTATIVE OFFICE

Str. Frederic Jolliot-Curie, Nr.3, Etaj 1, Ap.2, Sector 5
Bucharest, ROMANIA
TEL : 40-21-410-4170/4182/0984
FAX : 40-21-410-1178

KOYO DEUTSCHLAND GMBH.

Bargkoppelweg 4, D-22145 Hamburg, GERMANY
TEL : 49-40-67-9090-0
FAX : 49-40-67-9203-0

KOYO FRANCE S.A.

8 Rue Guy Moquet, B.P.189 Z.I., 95105 Argenteuil Cedex, FRANCE
TEL : 33-1-3998-4202
FAX : 33-1-3998-4244/4249

KOYO IBERICA, S.L.

Avda.da la Industria, 52-2 izda 28820
Coslada Madrid, SPAIN
TEL : 34-91-329-0818
FAX : 34-91-747-1194

KOYO ITALIA S.R.L.

Via Bronzino 9, 20133 Milano, ITALY
TEL : 39-02-2951-0844
FAX : 39-02-2951-0954

BEARING PLANTS

KOYO CORPORATION OF U.S.A. (MANUFACTURING DIVISION)

-Orangeburg Plant-

2850 Magnolia Street, Orangeburg, SC 29115, U.S.A.
TEL : 1-803-536-6200
FAX : 1-803-534-0599

-Richland Plant-

1006 Northpoint Blvd., Blythewood, SC 29016, U.S.A.
TEL : 1-803-691-4624/4633
FAX : 1-803-691-4655

JTEKT (THAILAND) Co., LTD.

172/1 Moo 12 Tambol Bangwua, Amphur Bangpakong,
Chachoengsao 24180, THAILAND
TEL : 66-38-531-988/993
FAX : 66-38-531-996

KOYO MANUFACTURING (PHILIPPINES) CORP.

Lima Technology Center, Municipality of Malvar, Batangas
Province, 4233 PHILIPPINES
TEL : 63-43-981-0088
FAX : 63-43-981-0001

KOYO JICO KOREA CO., LTD

28-12, Yulpo-Ri, Koduc-Myun, Pyung Teak-City, Kyungki-Do, KOREA
TEL : 82-31-668-6381
FAX : 82-31-668-6384

KOYO BEARING DALIAN CO., LTD.

No.II A-2 Dalian Export Processing Zone, 116600, CHINA
TEL : 86-411-8731-0972/0974
FAX : 86-411-8731-0973

WUXI KOYO BEARING CO., LTD.

Wuxi Li Yuan Economic Development Zone, Wuxi, 214072,
CHINA
TEL : 86-510-85161901
FAX : 86-510-85161143

DALIAN KOYO WAZHOU AUTOMOBILE BEARING CO., LTD.

No.96, Liaohe East Road, D.D Port, Dalian, 116620, CHINA
TEL : 86-411-8740-7272
FAX : 86-411-8740-7373

KOYO LIOHO (FOSHAN) AUTOMOTIVE PARTS CO., LTD.

No.12, Wusha Section Of Shunpan Road, Daliang Town, Shunde
Of Foshan, Guandong, Province, CHINA
(SHUNDE INDUSTRIAL PARK)
TEL : 86-757-22829589
FAX : 86-757-22829586

KOYO AUTOMOTIVE PARTS (WUXI) CO.,LTD.

B6-A New District, Wuxi, 214028, CHINA
TEL : 86-510-8533-0909
FAX : 86-510-8533-0155

KOYO BEARINGS (EUROPE) LTD.

P.O.Box 101, Elmhist Lane, Dodworth, Barnsley,
South Yorkshire, S75 3TA, UNITED KINGDOM
TEL : 44-1226-733200
FAX : 44-1226-204029

KOYO ROMANIA S.A.

Turnu Magurele Street No.1, 140003, ALEXANDRIA Teleorman
County, ROMANIA
TEL : 40-247-306-400
FAX : 40-247-306-421

TECHNICAL CENTERS

JTEKT CORPORATION NORTH AMERICAN TECHNICAL CENTER

47771 Halyard Drive, Plymouth, MI 48170, U.S.A.
TEL : 1-734-454-1500
FAX : 1-734-454-4076

JTEKT (CHINA) CO., LTD. TECHNICAL CENTER

Rm.1905, Aetna Tower, 107 Zunyi Road, Shanghai, 200051,
CHINA
TEL : 86-21-6237-5280
FAX : 86-21-6237-5277

JTEKT CORPORATION EUROPEAN TECHNICAL CENTRE

Markerkant 13-02, 1314 AN Almere, THE NETHERLANDS
TEL : 31-36-5383350
FAX : 31-36-5302656

Koyo® Roll neck bearings for rolling mill

Value & Technology



This catalog has been printed on paper of recycled paper pulp using environmentally friendly soy ink.

CAT. NO. B2013E
Printed in Japan '09.8-1CDS